



January 2016

A Comparative Analysis Of The Geology Tools Used During The Apollo Lunar Program And Their Suitability For Future Missions To The Moon

Lindsay Kathleen Anderson

[How does access to this work benefit you? Let us know!](#)

Follow this and additional works at: <https://commons.und.edu/theses>

Recommended Citation

Anderson, Lindsay Kathleen, "A Comparative Analysis Of The Geology Tools Used During The Apollo Lunar Program And Their Suitability For Future Missions To The Moon" (2016). *Theses and Dissertations*. 1860. <https://commons.und.edu/theses/1860>

This Thesis is brought to you for free and open access by the Theses, Dissertations, and Senior Projects at UND Scholarly Commons. It has been accepted for inclusion in Theses and Dissertations by an authorized administrator of UND Scholarly Commons. For more information, please contact und.common@library.und.edu.

A COMPARATIVE ANALYSIS OF THE GEOLOGY TOOLS USED DURING THE
APOLLO LUNAR PROGRAM AND THEIR SUITABILITY FOR FUTURE
MISSIONS TO THE MOON

by

Lindsay Kathleen Anderson
Bachelor of Science, University of North Dakota, 2009

A Thesis

Submitted to the Graduate Faculty

of the

University of North Dakota

in partial fulfillment of the requirements

for the degree of

Master of Science

Grand Forks, North Dakota

May
2016

Copyright 2016 Lindsay Anderson

This thesis, submitted by Lindsay Kathleen Anderson in partial fulfillment of the requirements for the Degree of Master of Science from the University of North Dakota, has been read by the Faculty Advisory Committee under whom the work has been done and is hereby approved.

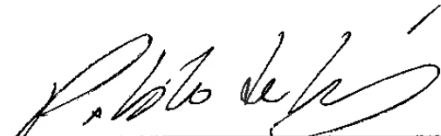

Dr. Pablo de León - Chairperson

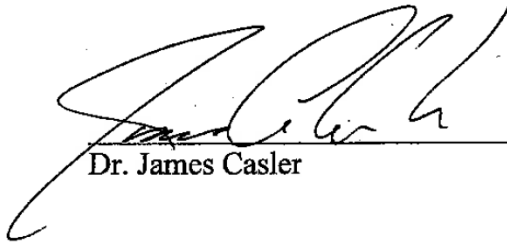

Dr. James Casler

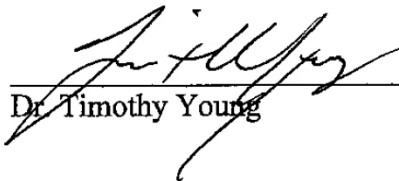

Dr. Timothy Young

This thesis is being submitted by the appointed advisory committee and having met all of the requirements of the School of Graduate Studies at the University of North Dakota is hereby approved.



Wayne Swisher
Dean of the School of Graduate Studies

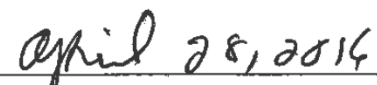

Date

PERMISSION

Title A Comparative Analysis of the Geology Tools Used During the Apollo
Lunar Program and Their Suitability for Future Missions to the Moon

Department Space Studies

Degree Master of Science

In presenting this thesis in partial fulfillment of the requirements for a graduate degree from the University of North Dakota, I agree that the library of this University shall make it freely available for inspection. I further agree that permission for extensive copying for scholarly purposes may be granted by the professor who supervised my thesis work or, in his absence, by the Chairperson of the department or the dean of the School of Graduate Studies. It is understood that any copying or publication or other use of this thesis or part thereof for financial gain shall not be allowed without my written permission. It is also understood that due recognition shall be given to me and to the University of North Dakota in any scholarly use which may be made of any material in my thesis.

Lindsay Kathleen Anderson
April 14, 2016

TABLE OF CONTENTS

LIST OF FIGURES	vii
LIST OF TABLES	xi
ACKNOWLEDGMENTS	xii
ABSTRACT	xiii
CHAPTER	
I. INTRODUCTION	1
II. BACKGROUND	3
Lunar Geology Equipment.....	3
Tools	3
Documented Sample Bags	16
Sample Stowage.....	18
NASA Requirements	19
NASA-STD-3000	21
NASA-STD-3001	25
JSC-0808-2A.....	28
JSC-26626A.....	28
NASA/SP-2010-3407	31
NASA/TP-2014-218556	34
NASA/TM-2007-214755	35
III. STATEMENT OF PROBLEM.....	37
IV. HYPOTHESIS	38
V. METHODOLOGY	39
Tool Selection	39

Tool Modification	40
Suit	41
Location	43
Regolith Simulant	45
Experiment.....	46
Experiment Design.....	46
Test Subjects	48
Layout	50
Procedure	52
Data Capture	55
Statistical Method	57
VI. RESULTS	58
General Test Observations.....	58
Scoop Target Test	59
Scoop Regolith Test.....	62
Rake Test	66
Tongs Test.....	69
VII. DISCUSSION AND CONCLUSIONS	74
VIII. FUTURE RESEARCH DIRECTIONS	78
Testing.....	78
Tool Modifications.....	81
Regolith Bin Testing.....	83
APPENDICES	88
REFERENCES	102

LIST OF FIGURES

Figure	Page
1. Apollo lunar geology tools (Apollo 17 Mission, 1973).....	3
2. Contact soil sampling device (Allton, 1989) (Apollo 16 Mission, 1972) (NASA photo S72-43792).....	5
3. Contingency soil sampler (Allton, 1989) (NASA photo S68-54937).....	6
4. Double length drive tube and ram (Allton, 1989) (NASA photo S71-16525).....	6
5. (a) is the original core tube bit used on the Apollo 11 mission	7
6. Core tube bit for Apollo 15 (Apollo 15 Preliminary 1972).	8
7. Fred Haise testing the drill at KSC	8
8. Drawing of bore stem joint prior to redesign (Apollo 15 Mission, 1971).....	9
9. Longer extension handle attached to a scoop (Allton, 1989) (NASA photo AS16-109-17846).....	10
10. Lighter weight hammer (Allton, 1989) (NASA photo S69-31847).....	11
11. Heavier weight hammer (Allton, 1989) (NASA photo S71-22471).....	11
12. LRV soil sampler (Allton, 1989)	11
13. Lunar soil rake (Allton, 1989)	12
14. Large, box-shaped scoop (Allton, 1989) (NASA photo S69-31846)	14
15. Small, non-adjustable scoop (Allton, 1989) (NASA photo S69-31850)	14
16. Small, adjustable-angle scoop (Allton, 1989) (NASA photo S71-22472).....	14
17. Large, adjustable-angle scoop (Allton, 1989) (NASA photo AS17-138-21160)	14

18. 32 inch tongs (Allton, 1989) (NASA photo S71-22469).....	15
19. Trenching tool (Allton, 1989) (NASA photo S71-2470).....	16
20. Cup-shaped documented sample bags in dispenser (Allton, 1989) (NASA photo AS12-49-7243)	17
21. LRV sampler, cup-shaped bags shown in the LRV sampler (Allton, 1989)	17
22. Flat, rectangular documented sample bags stowed pre-flight (Allton, 1989) (NASA photo S88-52669).....	18
23. Dispenser of later mission flat, rectangular documented sample bags (Allton, 1989)	18
24. ALSRC, Serial Number 09, flown on Apollo 12 and 16 (Allton, 1989) (NASA photo S72-37196).....	19
25. Apollo 16 ALSRC in LRL (Allton, 1989) (NASA photo S72-36984).....	19
26. Protective padded sample bag (Allton, 1989) (NASA photo S72-43790).....	19
27. "Exposed Corner and Edge Requirements" (Extravehicular, 1995).....	29
28. NDX-1 Planetary Suit.....	42
29. Demonstration of NDX-1 suit flexibility {Credit: NASA-JSC: Larry K. Dungan} ...	42
30. Regolith bin, Swamp Works NASA KSC {Credit: NASA-JSC: Larry K. Dungan} .	44
31. View through regolith bin	44
32. Regolith bin airlock and Don/Doff area.....	44
33. BP-1 Lunar Regolith Simulant (Suescun-Florez et al., 2015)	45
34. Table of minimum and maximum densities of Lunar regolith and assorted regolith simulants (Suescun-Florez et al., 2015).....	45
35. Scoop configurations	47
36. Rake configurations	48
37. Tong configurations shown with UND's tongs not those on loan from JSC	48

38. Targets arranged by diameter.....	50
39. Experimental set-ups, top-left rotating clock-wise; scoop target test, rake test, tongs test {Credit: NASA-JSC: Larry K. Dungan}, scoop regolith test	51
40. Scoop.....	53
41. Rake Head.....	54
42. Tongs provided by JSC and used for testing {Credit: NASA-JSC: Anthony D. Hood}.....	55
43. Set-up for small lab scale measurements	56
44. Large lab scale and speakers.....	56
45. Chart of total targets collected vs. configuration sorted by subject and unsuited/suited	60
46. 2-Sample t test of incidental regolith collected with orange targets, baseline to Configuration 2, both subjects suited.....	62
47. Chart of regolith collected vs. configuration sorted by subject and unsuited/suited ..	63
48. Chart of regolith/scoop vs. configuration sorted by subject and unsuited/suited	65
49. Chart of total targets collected vs. configuration sorted by subject and unsuited/suited	67
50. Chart of total targets dropped vs. configuration sorted by subject and unsuited/suited	68
51. 2-Sample t test of targets dropped, Configuration 3 to Configuration 2, both subjects suited.....	69
52. Chart of total targets collected vs. configuration sorted by subject and unsuited/suited	70
53. Chart of collection attempts by subject and configuration	71
54. Chart of dropped targets by subject and configuration.....	71
55. Chart of missed containers by subject and configuration	72
56. Air umbilical being fed into the regolith bin	84

57. Air umbilical being suspended from pulley system and tied off	84
58. "Body Size of the 40-year-Old American Male ... for Year 2000 in One Gravity Conditions" (Man-systems, 1995)	90
59. "Body Size of the 40-year-Old American Male ... for Year 2000 in One Gravity Conditions" (Man-systems, 1995)	91
60. "Body Size of the 40-year-Old American Male ... for Year 2000 in One Gravity Conditions" (Man-systems, 1995)	92
61. "Body Size of the 40-year-Old American Male ... for Year 2000 in One Gravity Conditions" (Man-systems, 1995)	93
62. "Body Size of the 40-year-Old American Male ... for Year 2000 in One Gravity Conditions" (Man-systems, 1995)	94
63. Scoop target test data collection sheet	95
64. Scoop regolith test data collection sheet, page 1	96
65. Scoop regolith test data collection sheet, page 2	97
66. Rake test data collection sheet	98
67. Tongs test data collection sheet	99
68. One-way ANOVA for incidental regolith compared by color, baseline configuration, both subjects suited	100

LIST OF TABLES

Table	Page
1. Tool measurements	41
2. List of tested tool modifications in order performed	47
3. Subjects' Anthropomorphic Measurements	49
4. Target sizes according to manufacturer	50
5. Target size; purple through black measured directly, red through green calculated	50
6. Scoop target test data	61
7. Scoop regolith test data	65
8. Rake test data	69
9. Tongs test data	72

ACKNOWLEDGMENTS

I would like to express my sincere gratitude to my thesis committee for the work they undertook during this study and the guidance they provided during my time at the University of North Dakota.

I also want to convey my thanks to NASA's Kennedy Space Center, Swamp Works, and NASA's Johnson Space Center for their support both during the set-up and execution of this testing, especially Jack Fox and Doug Gruendel, and many thanks to Joe Beardall for all of his work in the regolith bin and for his patience and good humor.

My family and friends have been indispensable throughout this time and I would very much like to express my appreciation for their support and confidence. Thank you to all who have helped support this research.

ABSTRACT

With the current push to return to planetary exploration it is important to consider what science will be performed on such missions and how it is to be performed. This study considered three hand tools used for geologic sampling during the Apollo missions to determine whether handle redesigns guided by NASA-STD-3001 improved the performance of the tools. The tools of interest were the large adjustable scoop, the rake, and the 32-inch tongs, selected for relevance and usability in the test location. The three tools with their original and modified handle diameters were tested with two subjects wearing the NDX-1 Planetary Suit and performed within the regolith bin operated by Swamp Works at Kennedy Space Center. The effects of the tool modifications on task performance did not conclusively demonstrate improvement. However, a methodology was developed that may prove beneficial in future tests using larger sample sizes.

CHAPTER 1

INTRODUCTION

During the 1960s and 1970s, twelve men walked on the lunar surface during the course of six Apollo missions. It was the first time a human set foot on another planetary body and, to accomplish the goals of the Apollo program, a vast array of equipment needed to be designed for use in a reduced gravity environment. Toward the accomplishment of one of these goals, each lunar landing visited a unique area of the near side of the Moon and returned an selection of samples that is still being studied today. Geology tools had to be designed to collect these important samples and, since this was the first time such tools had to be fabricated, tool development progressed along with the program.

Several of the tools underwent modifications as experience was gained during the landings and other tools were added to better accomplish the lunar exploration. With the difficulties of working in such an environment it is no wonder that issues would be found and changes made. However, NASA standards have been changed and updated since the Apollo missions and the tools may no longer meet all the requirements set out for flight hardware. If these tools were to be redesigned to such standards would the performance changes be measurable or perceived by the astronauts using them? For this research one area of tool design was the focus, the diameter of the handles.

This study was designed, in part, based on a unique opportunity afforded by NASA's Kennedy Space Center (KSC). The University of North Dakota's (UND) Human

Spaceflight Laboratory was given the opportunity to perform the first suited test in the regolith bin operated by Swamp Works. This study was then refined to work within the time available and the physical constraints of an indoor facility.

Since the end of the Apollo program no human has set foot on non-terrestrial ground, but it would seem that humanity wishes to return. If this is true, then preparations for such missions cannot start too soon, and among these preparations must be a look at how best to gain all the scientific knowledge that is possible. Looking at something as basic as field geology tools, especially those that may also double as maintenance tools, will need to be done. Since Apollo is the only in situ data available, it would seem prudent to make that the start for such an effort.

CHAPTER II
BACKGROUND

Lunar Geology Equipment

The background of the Apollo geology tools was researched to ensure that the selected tools for this study were still being used at the end of the Apollo lunar landings and fit the experiment design and location. A review of the types of containers available for the Apollo sample returns was completed as part of designing the study's procedure.

Tools

There were several hand geology tools utilized during the Apollo lunar surface operations, some can be seen in Figure 1. They included the contact soil sampling device,

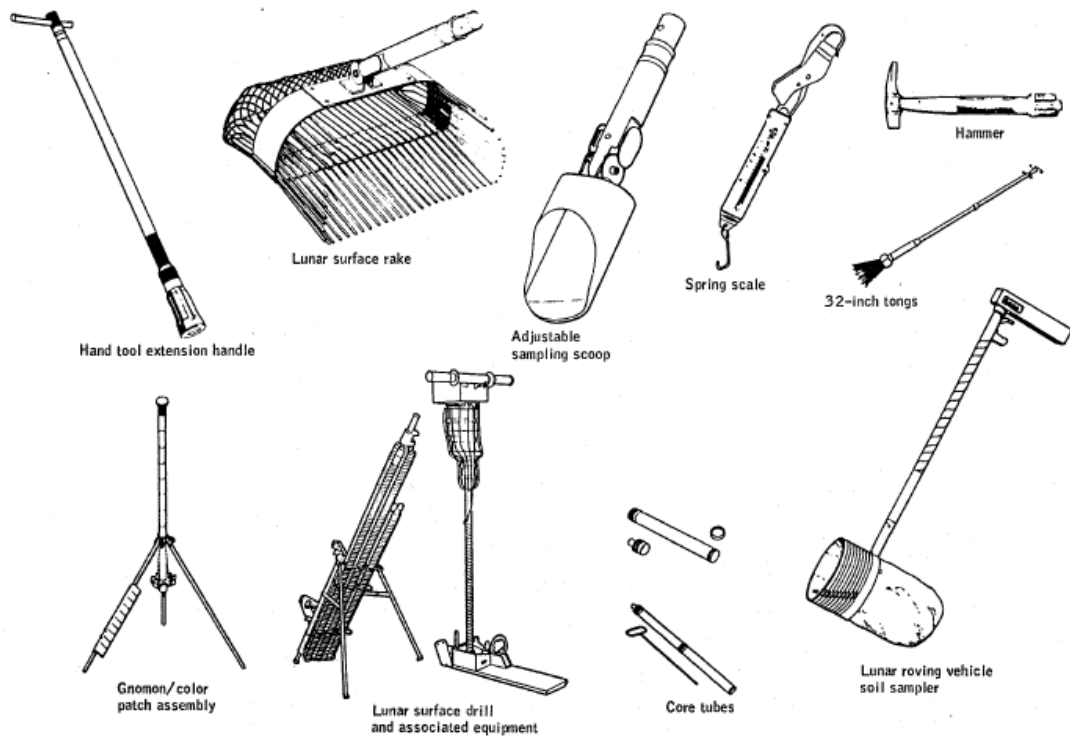

Figure 1. Apollo lunar geology tools (Apollo 17 Mission, 1973).

contingency soil sampler, core/drive tube, drill, hammer, lunar rover soil sampler, rake, scoop, tongs, and trenching tool. Included is also an extension handle that was used for various tools. Not all of these tools were used consistently throughout the program and some were modified to correct for deficiencies reported during use on the lunar surface (Allton, 1989). These tools were sometimes used outside of their design envelope and it was reported that the tools, such as the scoop, could be used to lean on while astronauts retrieved objects from the lunar surface and aided them when they wanted to stand up again (Apollo 11 Technical, 1969). It is important to keep in mind that the Apollo surface operations were the first manned planetary operations and the tools were not designed with modern extravehicular activity (EVA) standards in mind. Observations on how the tools worked, and how they were used can be found in various NASA documents, along with the kinds of samples they were used to collect.

For the most part the Apollo 11 crew observed that the geology tools they used were suitable and useful (Apollo 11 Mission, 1969). The tools of Apollo 11 and 12 were nearly indistinguishable from each other (Apollo 12 Mission, 1970). One general observation made by a crewmember of Apollo 12 was that the tools with a shiny finish, such as the tongs, would seem to increase the temperature of his hands. This was not noted as being uncomfortable or a danger and would end when the tool was released. It was also noted that some of the tools seemed "flimsy" and that a crewmember should not feel worried about possibly breaking something because it was not sound enough (Apollo 12 Technical, 1969). The Apollo 14 crew reported that the "geology hand tools are good" (Apollo 14 Mission, 1971). The crew of Apollo 15 stated that the "equipment used during the geology portion of the extravehicular activities performed well". They did have a

couple of issues, one with the gnomon not discussed here and one when a seal on an Apollo lunar sample return container did not work correctly due to a sample bag in the way (Apollo 15 Mission, 1971). The Apollo 17 crew that worked on the lunar surface, noted that tools that are to be gripped for extended time periods should have custom grips. In this case, the hammer grip was too large for one crewman's hand, but fit the others well. Beyond this observation, they said the tools worked as anticipated (Apollo 17 Mission, 1973).

Contact Soil Sampling Device (Lunar Surface Sampler Tool). The contact soil sampling device's purpose was to sample only the very top layers of the lunar regolith. The sampler was only utilized on Apollo 16 and was actually flown as a set of two (Allton, 1989). One sampler had velvet covering on the contact surface and the second had beta cloth. The purpose of the different materials was to sample the uppermost regolith layer to different depths (Apollo 16 Mission, 1972). Figure 2 shows a contact soil sampling device both open, ready to sample and closed for transport. The universal hand tool (UHT) was used as a handle for the soil samplers (Apollo 16 Mission, 1972). The

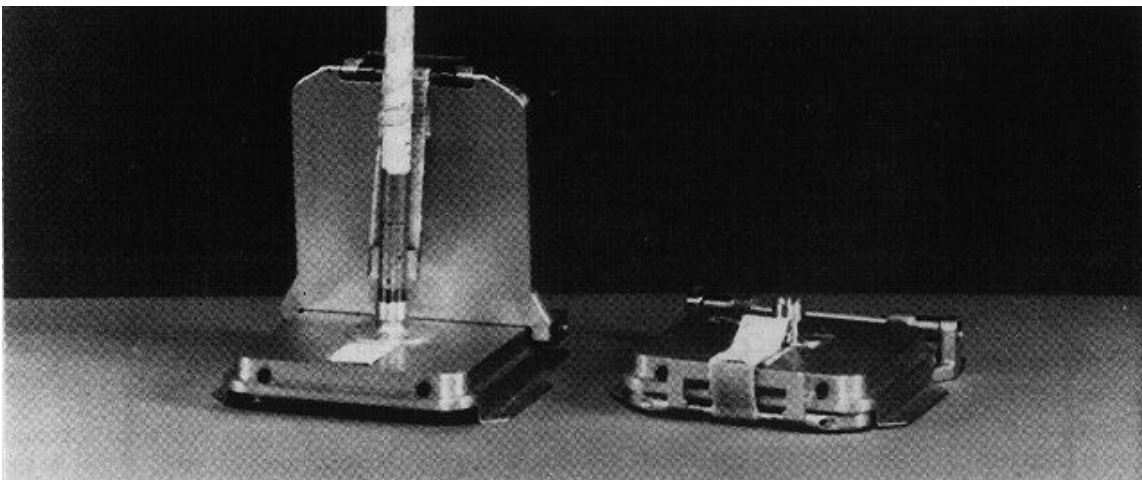

Figure 2. Contact soil sampling device (Allton, 1989) (Apollo 16 Mission, 1972) (NASA photo S72-43792).

UHT was a "special long-handled allen wrench which doubles as a handling tool" (Apollo 14 Lunar, 1989).

Contingency Soil Sampler. The contingency soil sampler's purpose was to ensure a sample return from the lunar surface even if operations terminated before more extensive samples could be taken, Figure 3. This piece of equipment was utilized on Apollo 11, 12, 14, and 15. The diameter of the bag was 10 cm (Allton, 1989).

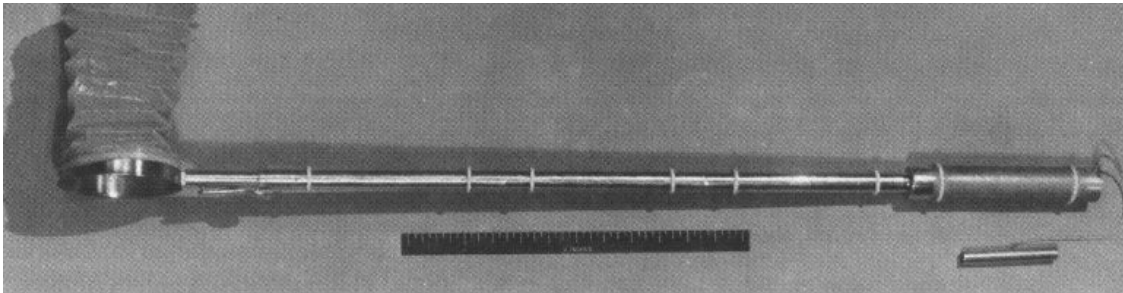

Figure 3. Contingency soil sampler (Allton, 1989) (NASA photo S68-54937).

Core/Drive Tube. The purpose of the core and drive tubes was to retrieve lunar samples in which the stratigraphy of the upper layers of the regolith would be preserved for study, Figure 4 (Apollo 11 Mission, 1969). The core and drive tubes had a more

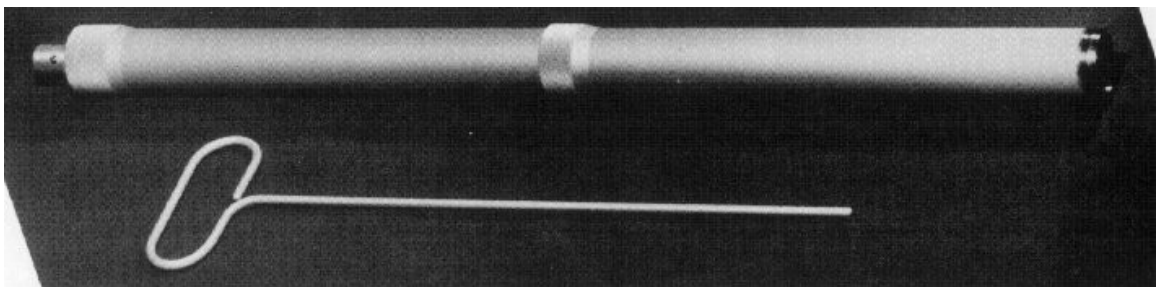

Figure 4. Double length drive tube and ram (Allton, 1989) (NASA photo S71-16525).

complicated development during the Apollo missions than most of the geology tools. The core tube was employed first and had two different bits (Allton, 1989). The original configuration was only flown on Apollo 11. This included the original inverted funnel-shaped bit (Allton, 1989), which compressed the sample and increased the resistance (Apollo 11 Mission, 1969). Apollo 12 and 14 used the core tube, but with a second,

tapered bit design, see Figure 5 (Allton, 1989). The Apollo 12 design also compacted the soil with the consequence that even after the tube had been driven to its greatest depth the core tube still would not be filled to its entire length (Apollo 12 Mission, 1970). The core tubes were designed to have the extension handle attached and be driven into the soil

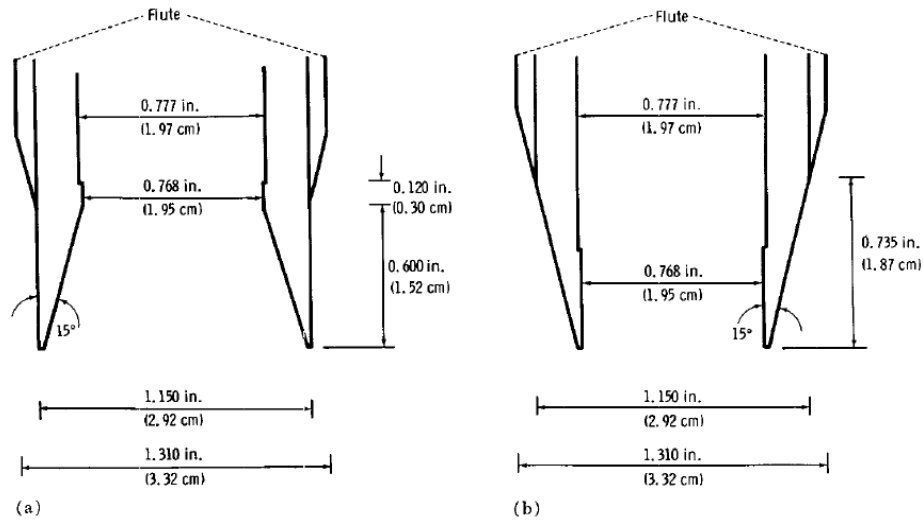

Figure 5. (a) is the original core tube bit used on the Apollo 11 mission. (b) is the bit used for the core tube on Apollo 12 and 14 (Apollo 12 Preliminary, 1970).

with a hammer. Within the tube there was a "follower" that was placed at the bottom of the tube before flight. As the tube was driven down, the follower moved up the tube, pushed by the soil, and retained the upper soil in the tube. Two core tubes could be screwed together to get a deeper sample (Allton, 1989).

To deal with issues that came from the design of the core tube, the design was modified. The main issues intended to be addressed by the redesign were "(1) to reduce the amount of sample disturbance, (2) to increase the size of the sample, and (3) to facilitate ease of sampling by the crew" (Apollo 15 Preliminary, 1972). The revised design was flown on Apollo 15, 16, and 17. The main improvement over the core tube was the increased inner diameter and decreased wall thickness. Another change was that the "follower" was replaced by a "keeper". This was placed at the top of the tube and,

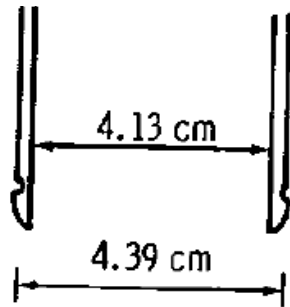

Figure 6. Core tube bit for Apollo 15 (Apollo 15 Preliminary 1972).

only after the sample was taken, was pushed down to meet the top of the regolith sample to help maintain sample integrity (Allton, 1989). There was also a redesigned bit, see Figure 6 (Apollo 15 Preliminary, 1972). Once again, the sections could be screwed together to lengthen the sample that could be taken (Allton, 1989).

Drill. The rotary-percussive drill was flown on Apollo 15, 16, and 17 to collect core samples and to drill placement holes for the heat flow probes, see Figure 7. The

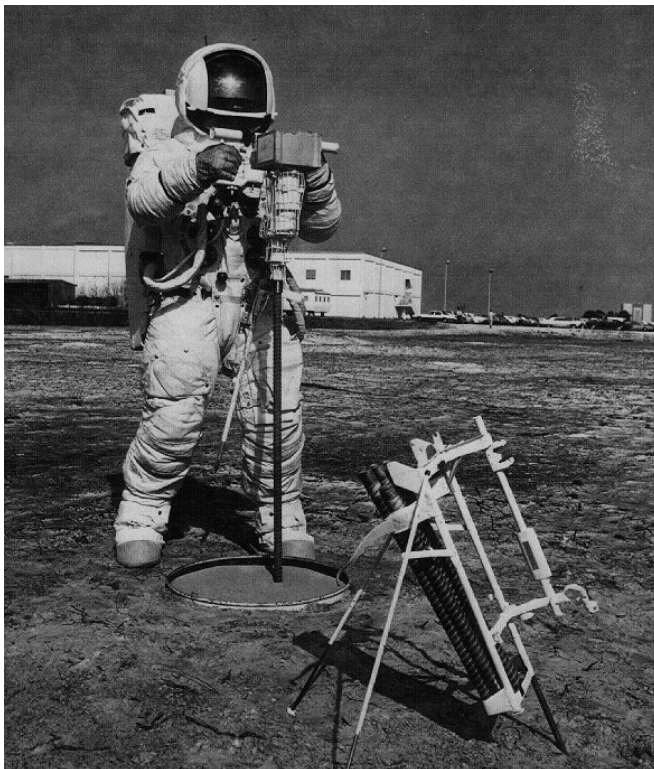

Figure 7. Fred Haise testing the drill at KSC. The image clearly shows the main parts of the drill; handle, battery, power head, and drill stems. In the foreground is a stand retaining bore stems (Allton, 1989) (NASA photo S70-29673).

Apollo 15 and 16 drills were used with six core stem tubes and increased to eight core stems on Apollo 17 (Allton, 1989). The core stems had fluting on the exterior walls to allow for transport of cuttings up and out of the way of the drilling. With the material used for the Apollo 15 model the fluting disappeared around the core stem joints, which caused some binding,

see Figure 8. To fix this for the following missions the joint of the

bore stems was changed from "boron/fiberglass tapered joints" and was replaced with "threaded titanium inserts which provide continuous flutes". The section lengths were

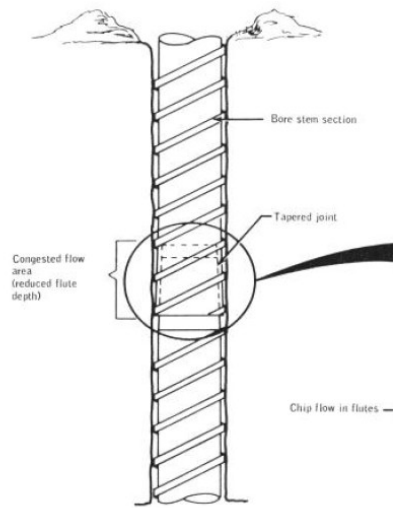

Figure 8. Drawing of bore stem joint prior to redesign (Apollo 15 Mission, 1971).

also increased, reducing the number of joints necessary (Apollo 15 Mission, 1971). With eight core stem tubes a sample could reach three meters in length. After drilling was completed, the core stems were removed from the surface by a jack utilizing the treadle (Allton, 1989). The "mechanical assist (modified jacking mechanism)" was not added to the treadle until after the Apollo 15 flight, in response to some of the issues they had (Apollo 15 Mission, 1969).

Extension Handle. Two different extension handles were flown during the Apollo missions. The first is referred to as the shorter extension handle and the revised version is the longer extension handle, pictured in Figure 9. The purpose of the extension handles was to be a kind of general tool handle that could be attached to multiple different tool heads to help reduce the mass of equipment flown. When attached to the drive/core tubes it was used as a driving surface to hammer against. It could also be attached to the hammer, scoop, and rake. In each of these instances its purpose was either to help increase leverage or reach length (Allton, 1989). While there were times that the extension handles were necessary, the Apollo 11 crew observed of lunar sample collection that "crewmembers may want to consider kneeling in order to work with their hands. Getting to and from the kneeling position would be no problem, and being able to do more work with the hands would increase the productive capability" (Apollo 11 Mission, 1969).

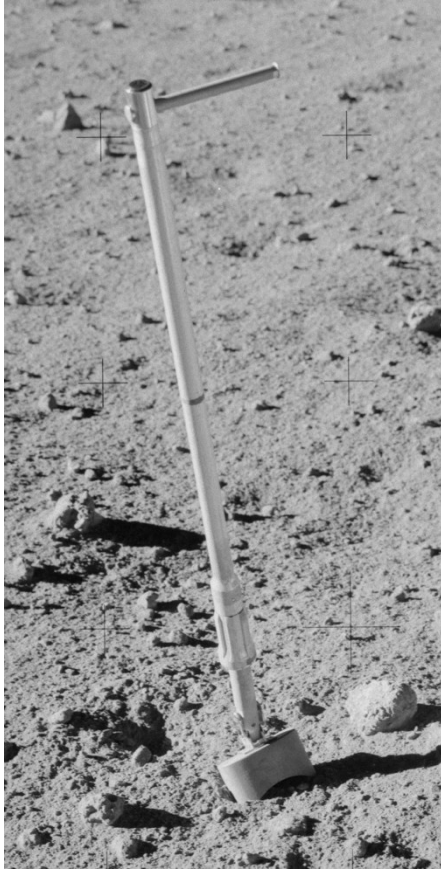

Figure 9. Longer extension handle attached to a scoop (Allton, 1989) (NASA photo AS16-109-17846).

The shorter extension handle had a mass of 590 g and a total length of 61 cm. The handle had a "T" form and a width of 15.5 cm. The aluminum was reinforced with stainless steel where the handle was designed to be struck with the hammer. This handle design was flown on Apollo 11 and 12 (Allton, 1989). On Apollo 12, the crew reported they could have dug to greater depths on the lunar surface except that the length of the extension handle wouldn't permit it and, when used with the "shovel", it was 3 inches to 5 inches too short (Apollo 12 Mission, 1970). The longer extension handle was used for the remainder of the Apollo flights; 14, 15, 16, and 17. The overall length of this design was 76

cm with the same 15.5 cm width for the t-handle. However, more of the t-handle had been reinforced with stainless steel. The Apollo 14 mass is listed as 770 g, while the mass listed for Apollo 15, 16, and 17 is listed as 820 g. The aluminum alloy and the stainless steel that was used on the shorter extension handle was also changed for the longer extension handle (Allton, 1989).

Hammer. There were two hammer designs for the Apollo missions. Both could be used with extension handles and functioned to collect rock chips from boulders, sink core/drive tubes, and to trench. The lighter weight hammer was used for Apollo 11 and 12, Figure 10 (Allton, 1989). The heavier weight hammer, Figure 11, was used for

Apollo 14, 15, 16, and 17, though minor changes were made during these missions as well (Allton, 1989). The astronauts of Apollo 17 said the hammer grip was a good size for one, but it was much too large for the other astronaut (Apollo 17 Mission, 1973).

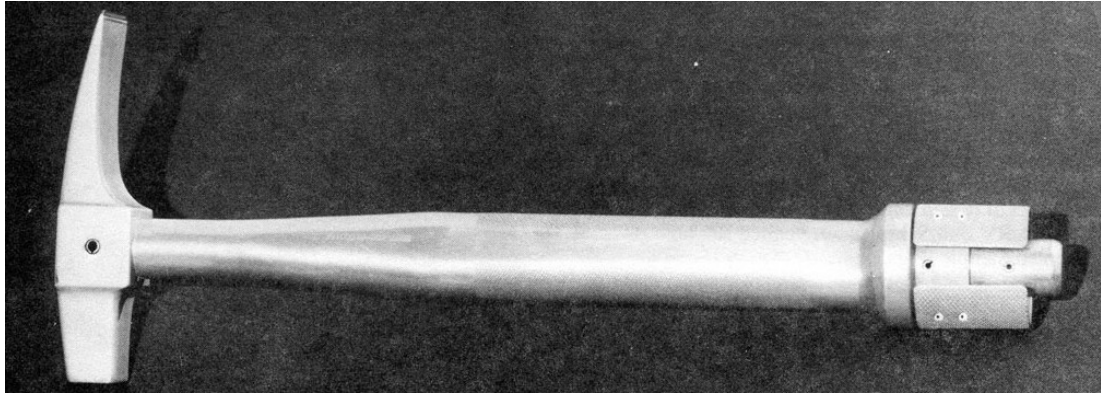

Figure 10. Lighter weight hammer (Allton, 1989) (NASA photo S69-31847).

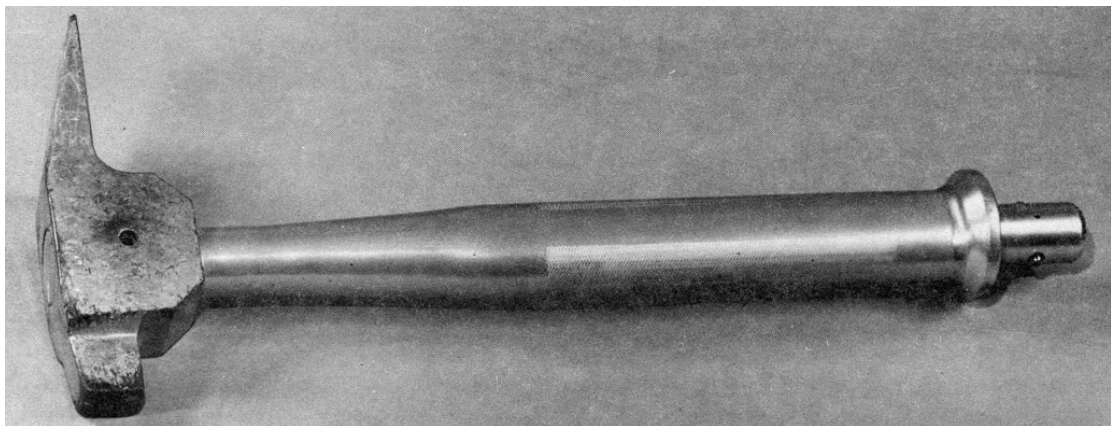

Figure 11. Heavier weight hammer (Allton, 1989) (NASA photo S71-22471).

Lunar Roving Vehicle (LRV) Soil Sampler. The LRV soil sampler, Figure 12,

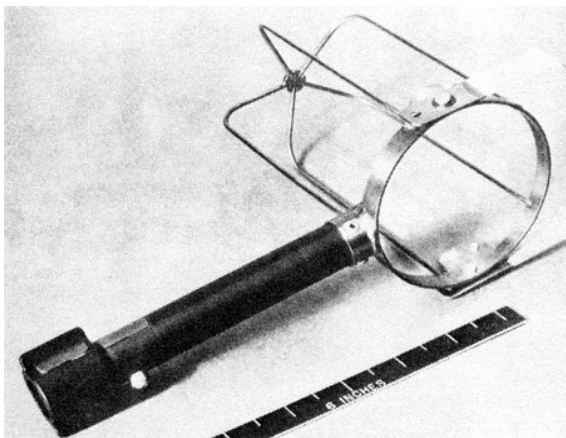
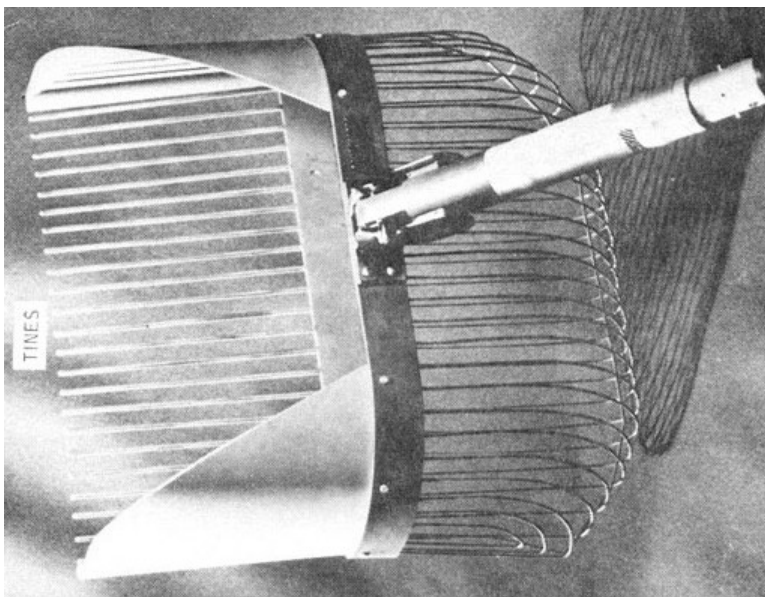

Figure 12. LRV soil sampler (Allton, 1989).

was designed to allow for sample collection by an astronaut from within the LRV. This was designed and implemented to save the time and effort of astronauts having to get out of and back into the rover to collect samples. The head of the LRV

soil sampler was attached to the UHT to allow for the necessary reach. This tool was only flown on Apollo 17 (Allton, 1989). The Apollo 17 crew observed that the LRV sampler worked well for sampling from the rover and also reported using it for some sampling while walking (Apollo 17 Mission, 1973).

Lunar Soil Rake. The lunar soil rake was designed to collect pebbles greater than 1 cm in size from within the regolith. It had a mass of 1500 g and the portion of the handle seen in Figure 13 has a length of 22.3 cm. The rake head was then attached to an



extension handle
(discussed previously).

Both the total length of the basket and the mouth were 29.4 cm and the height was 10.4 cm with a wire separation of 1 cm. The basket wires were stainless

Figure 13. Lunar soil rake (Allton, 1989).

steel and the sidewalls of

the rake's mouth were aluminum alloy. The rake was flown on Apollo 15, 16, and 17 (Allton, 1989). Its purpose was to "give a statistical sampling of rocks in the size range between soil and the average documented sample" (Apollo 15 Preliminary Report, 1972).

The first crew to use the rake, Apollo 15, said it "worked well" and also could function as a scoop (Apollo 15 Mission, 1971). The Apollo 16 crew also believed the rake worked well for sampling. However, they did report having some issues when using it in thin regolith layers, such as bending the tines. To help mitigate the problems of

raking in thin regolith, they would kick material into the rake and sieve the material through the rear of the rake. This was a method that had been practiced in ground training (Apollo 16 Technical, 1972). The Apollo 17 crew reported that the joint on the rake became stiff after repeated use and was no longer able to be locked after adjustment (Apollo 17 Technical, 1972).

Scoop. The purpose of the scoop was to collect rock fragments, perform minor trenching (Apollo 11 Mission, 1969) and collect regolith samples (Allton, 1989), as well as collect regolith and rock samples together (Apollo 11 Lunar, 1969). The regolith collection was made more difficult due to the reduced lunar gravity. The material being collected would be driven upward into an arc so a rotating movement while scooping was necessary (Allton, 1989). A full scoop of material was nearly unobtainable and filling the container took around twice the time anticipated (Apollo 11 Mission, 1969).

There were a total of four different scoops used throughout Apollo surface operations. The large, box-shaped scoop, Figure 14, was used during Apollo 11, 12, and 14. The small, non-adjustable scoop, Figure 15, was employed on Apollo 12 and 14. The large, box-shaped scoop and the small, non-adjustable scoop were both made of aluminum. The small, non-adjustable scoop had a stainless steel reinforced edge and top to allow it to be used as a chisel. The small, adjustable-angle scoop, Figure 16, was flown only on Apollo 15. The large, adjustable-angle scoop, Figure 17, was utilized on Apollo 16 and 17. The small, adjustable-angle scoop and the large, adjustable angle scoop were made from stainless steel and were designed to collect samples both by pushing and pulling the scoop. They were all designed to be attached to the extension handles (Allton, 1989). The large, adjustable-angle scoop, the last version flown, could be set from 0°

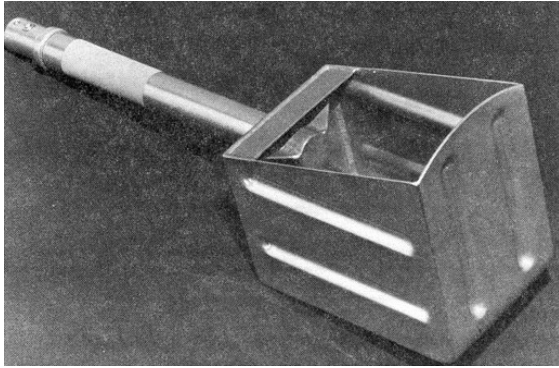

Figure 14. Large, box-shaped scoop (Allton, 1989) (NASA photo S69-31846).

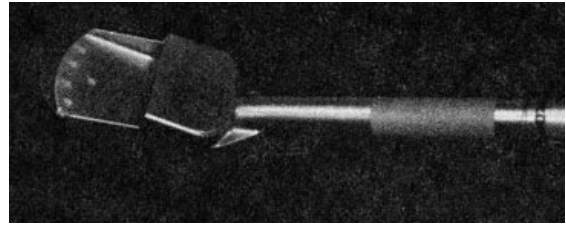

Figure 15. Small, non-adjustable scoop (Allton, 1989) (NASA photo S69-31850).

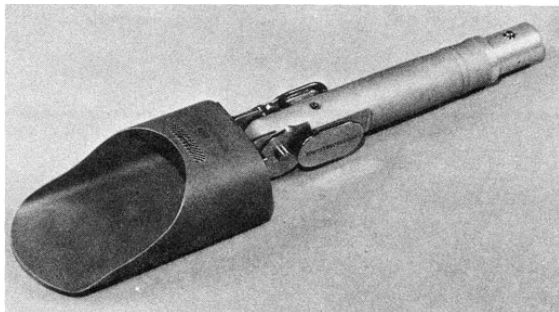

Figure 16. Small, adjustable-angle scoop (Allton, 1989) (NASA photo S71-22472).



Figure 17. Large, adjustable-angle scoop (Allton, 1989) (NASA photo AS17-138-21160).

(horizontal) - 55° for sampling and to 90° for trenching (Apollo 17 Mission, 1973). It also had a mass of 590 g and an overall length of 35.4 cm. The head had a height of 5.1 cm, width of 11.4 cm, and a length of 15.2 cm (Allton, 1989). The Apollo 17 crew reported that the large, adjustable-angle scoop worked well and was their principal tool for sampling, but by their third EVA only one angle position was useable (Apollo 17 Mission, 1973) because adjusting and locking the joint wasn't possible (Apollo 17 Technical, 1972).

Tongs. There were two different tong lengths used for Apollo surface operations. The shorter were used during Apollo 11, 12, and 14 and the longer, 32-inch tongs were used during Apollo 15, 16, and 17. Both tongs appear to be of similar construction, tine and handle style but the tine material for the shorter tongs was aluminum and on the 32-inch tongs the tines were stainless steel. The 32-inch tongs, the last version flown, were

230 g, had an overall length of 80 cm, and a 12 cm wide t-handle (Allton, 1989), Figure 18. The handle length of the tongs was 28 inches (Apollo 17 Mission, 1973). The tongs were designed to retrieve lunar sample rocks that were smaller than 6 - 10 cm (Allton, 1989).

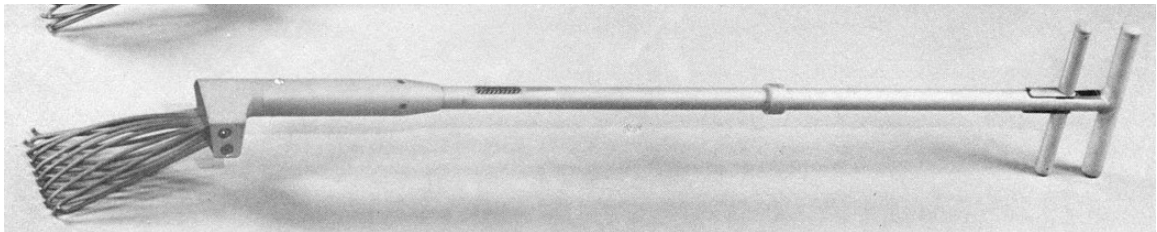

Figure 18. 32 inch tongs (Allton, 1989) (NASA photo S71-22469).

The Apollo 11 crew also used their tongs to right a camera that had been upset during their surface operation, as they were also designed with the idea of "retrieving tools that might have been dropped", along with documented samples (Apollo 11 Mission, 1969). The tongs were certainly used during the missions, but it was also suggested that a normal operating mode should be kneeling on the lunar surface to collect samples and thus "allow closer inspection of the lunar surface". The Apollo 12 crew observed that the tongs were 3 to 5 inches too short to readily retrieve lunar surface samples (Apollo 12 Mission, 1970) and that the jaw of the tongs only allowed for retrieval of small rocks and thus the samples were biased toward the small rocks (Apollo 12 Technical, 1969). The Apollo 15 crew reported that by their third EVA the tongs had become problematic and the backup pair had to be used. The second pair functioned as they were supposed to (Apollo 15 Mission, 1971). This malfunction was in part due to pushing them into the lunar soil to store them in between uses as the original storage attachment to the suits no longer worked (Apollo 15 Technical, 1971).

Trenching Tool. The trenching tool, Figure 19, was designed to dig trenches on the lunar surface. The joint attaching the blade to the handle allowed for the angle of the

trenching tool to be adjusted. This tool was only flown on Apollo 14. The large, adjustable-angle scoop was used in place of the trenching tool in later missions (Allton, 1989).



Figure 19. Trenching tool (Allton, 1989) (NASA photo S71-2470).

Documented Sample Bags

Documented sample bags were used to store individual samples and then were placed inside other, larger containers for the flight back to Earth. Several documented sample bags could fit inside the larger containers along with larger, loose rock samples. The documented sample bags were numbered and had ways to be sealed to allow for samples to be identifiable and discrete (Allton, 1989). To document the bags, the numbers printed on the bags were reported to ground control during sampling (Apollo 12 Mission, 1970).

The following sections detail the various documented sample bags as they are described by Allton in *Catalog of Apollo Lunar Surface Geological Sampling Tools and Containers* (1989) and then gives a brief description of some of the larger containers used to store the samples for the return flight.

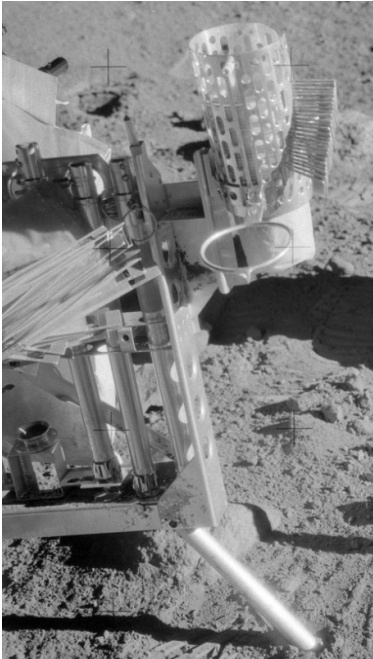

Figure 20. Cup-shaped documented sample bags in dispenser (Allton, 1989) (NASA photo AS12-49-7243).

Cup-shaped Documented Sample Bag. The cup shaped bags were placed in a dispenser that was attached to the small tool carrier and carried a stack of thirty-five cups at a time (Allton, 1989), see Figure 20. The cups were 3.25 inches in diameter with a depth of 5.25 inches (Apollo 17 Mission, 1973). These were used with their dispenser on Apollo 12 and 14 (Allton, 1989).

LRV Soil Sampler Bag. These bags were only used with the LRV soil sampler and as such were only flown for Apollo 17, see Figure 21. Each was 8 cm in diameter with a depth of 13 cm (Allton, 1989).

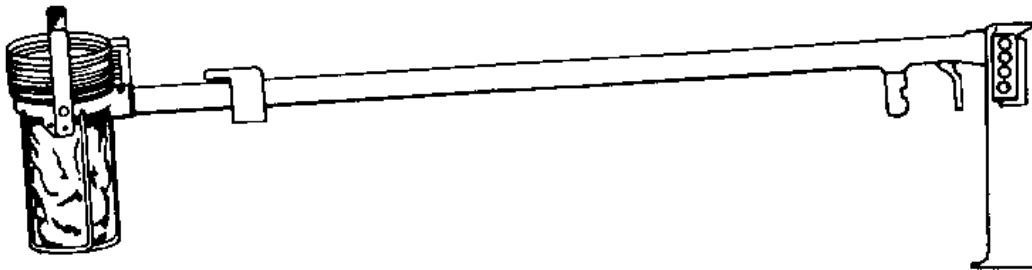

Figure 21. LRV sampler, cup-shaped bags shown in the LRV sampler (Allton, 1989).

Flat, Rectangular Documented Sample Bags.

Early Missions. For Apollo 12 and 14 these bags were 15 cm x 15 cm and were dispensed from a metal cylinder (Allton, 1989). The closure tabs had a tendency to entangle so detaching a bag became problematic and reportedly it was very difficult to only take one bag at a time. Typically two or three would come off and some would become lost (Apollo 14 Mission, 1971; Apollo 14 Technical, 1971). The Apollo 12 crew

stated that the "tear-away" bags were the easier of the documented sample bags to use but they were too small to package the more desired rock samples (Apollo 12 Mission, 1970).

Later Missions. The Apollo 15, 16, and 17 missions flew larger, flat, rectangular documented sample bags, Figures 22. The dispenser was designed to make opening the bags simpler for the suited astronauts, Figure 23. These bags were designed with up to an 11 cm diameter rock in mind (Allton, 1989).



Figure 22. Flat, rectangular documented sample bags stowed pre-flight (Allton, 1989) (NASA photo S88-52669).

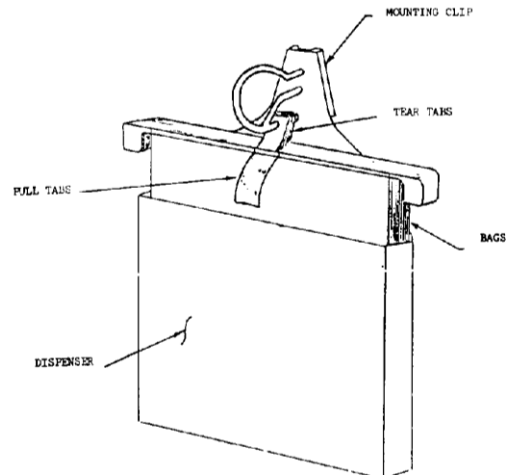

Figure 23. Dispenser of later mission flat, rectangular documented sample bags (Allton, 1989).

Sample Stowage

The Apollo lunar sample return container (ALSRC), also referred to as a rock box, was the main storage for samples returning from the Moon, see Figures 24 and 25. They were designed with the idea of keeping the samples in a "lunar-like vacuum" until the boxes were opened at the Lunar Receiving Laboratory (LRL). The boxes had exterior dimensions of 48 cm x 27 cm x 20 cm with a typical wall thickness of 2 mm, not taking into account the reinforcing ribbing. All Apollo missions flew two ALSRCs (Allton, 1989).

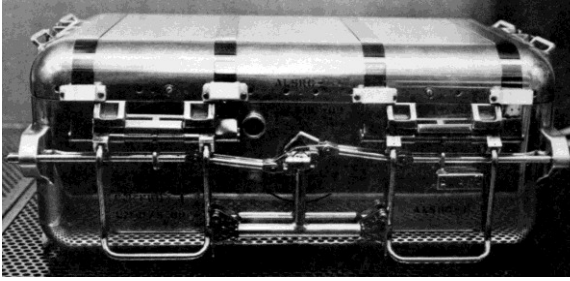

Figure 24. ALSRC, Serial Number 09, flown on Apollo 12 and 16 (Allton, 1989) (NASA photo S72-37196).



Figure 25. Apollo 16 ALSRC in LRL (Allton, 1989) (NASA photo S72-36984).

The purpose of the protective padded sample bag, Figure 26, was to provide



Figure 26. Protective padded sample bag (Allton, 1989) (NASA photo S72-43790).

protection to more fragile samples and help avoid abrading rock surfaces. Two of these bags were flown on Apollo 16. The majority of the bag was made from teflon ribbon and film. They employed a double closure that included an aluminum tab and Velcro. The mass of one bag was approximately 220 g with a padded volume of 15

cm x 14 cm x 5 cm (Allton, 1989).

There were other containers and bags flown on Apollo missions (Allton, 1989) which are not covered here as they either do not pertain to taking regolith or rock samples.

NASA Requirements

Design considerations for any systems intended for the purpose of manned space flight are governed by NASA standards and NASA center standards, as well as influenced by other NASA documentation, such as technical papers. Standards can either be all encompassing or geared toward a specific area of spaceflight, e.g., medical, controls, EVA. Hand held equipment, such as tools, can fall under two different

categories: those which are designed to be used within a pressurized environment, such as the International Space Station (ISS), and are therefore to be used unsuited, and those which are to be used outside the confines of living quarters, either in microgravity or reduced gravity, and must be able to be operated while suited.

Tools purposefully made to be manipulated by suited astronauts must be designed to address multiple concerns. First, design must address the degradation of both fine motor function and gross motor function that occurs while suited. Second, fatigue develops more quickly while working within a suit and against suit pressure when compared with the performance of unsuited operations. Third, the apparatus must pose no probable threat to the person inside the suit. Finally, the tool may not cause foreseeable damage to the spacesuit. These requirements are considered in various NASA documentation with the purpose of making EVAs more productive and ensuring the safety of the people not only performing the operations, but also those around them.

This section will focus on the requirements and recommendations that apply to tools designed for EVA operations on an extraterrestrial surface that are most pertinent to the topic of this paper. Often equipment design requirements come from the experience that is gained from previous missions and designs. The experiences to draw from for the development of EVA standards that apply to suited, reduced gravity surface operations are limited. Though these conditions have been simulated, only twelve humans have ever worked in this actual environment. The majority of EVA experience is from the microgravity environment and, while some EVA issues are shared between environments, requirements between these two types of EVA vary. Issues associated with microgravity EVAs include floating objects, translation paths along spacecraft, and

remaining anchored or tethered during work. Reduced gravity, surface EVA participants need to be able to work at different levels and in multiple eye lines, pick things up from the surface, traverse distances, and minimize dust and regolith impeding tool and suit operations. Surface EVAs can be geared toward different mission objectives. The Apollo landings were of a short enough duration that major maintenance and repairs were not needed and their EVAs were primarily used to set up experiments and gather scientific samples. Microgravity EVAs, particularly those programmed for the ISS, have been focused more on equipment tests, construction, maintenance, and repair.

NASA-STD-3000

NASA-STD-3000, the Man-Systems Integration Standards (MSIS), was last updated in 1995. It replaced previous "NASA field center human engineering standards documents" and integrated principles of other standards from "NASA, military, and commercial human engineering" documents when they were found to be pertinent. This was done to create "a single, comprehensive document defining all generic requirements for... equipment which directly interfaces with crewmembers" (Man-systems, 1995). The requirements and sections relevant to surface EVA tool design follow.

Section 2 of the MSIS deals with general requirements. One principle is to keep designs as simple as may be. This reduces the likelihood of failures and will typically allow for less necessary training due to simpler operational requirements. The second important concept is standardization. For the purpose of EVA tool design, this would imply consistently using the same hardware for assembly, ensuring a minimum number of maintenance tools required (Man-systems, 1995).

Section 3 of the MSIS is about anthropometry and biomechanics. In the case of EVA tools, the tools must be manipulated through the medium of the suit, which influences measurements such as optimal grip size or mean grip strength. Here anthropomorphic measurements are to be based on the actual user population. The difficulty in this comes from the wide variety of people currently represented in the space program and thus the great differences that can be seen among crew members of any given mission. The MSIS gives data at its own defined end points of user population and considers "the 5th percentile Asian Japanese and the 95th percentile White or Black American male projected to the year 2000." (Man-systems, 1995).

Any equipment that is flown must accommodate this variety of possible users. To accomplish this goal the MSIS gives three strategies that can be utilized:

- "Single Size For All" - This can be accomplished when using either the minimum or maximum data point allowed for one crewmember for use by the whole crew (Man-systems, 1995). An instance where this strategy would work is in designing for reach. If a tool, perhaps a pair of tongs, allows the tallest person to comfortably retrieve an object from the ground, then the shortest crew member should also be able to perform this task.
- "Adjustment" - Using this strategy the same piece of equipment can be altered to allow easy use by different people (Man-systems, 1995). This principle could be seen when allowing a tool head to be locked at different angles.
- "Several Sizes" - Sometimes the differences in measurements are simply too large and the best way to accommodate the entire crew is to produce more than one of a single piece of equipment in various sizes (Man-systems, 1995). Especially when

suited, the grip size of a tool handle may be important in keeping an astronaut comfortable and productive. Producing custom grips for each astronaut would be an example of the this strategy.

Anthropomorphic measurements are given in 1-G conditions with notes on how these measurements are expected to change in microgravity. The measurements do not address reduced gravity conditions or transferring from 1-G to microgravity to reduced gravity or the reverse. Clothing need not be taken into account when determining body size in most habitable space when under shirtsleeve conditions. However, "[w]hen an individual must wear an EVA pressure garment or a space suit, body dimensions will be affected drastically. In this case, dimensional studies must be made for the user population wearing the garment" (Man-systems, 1995).

Section 4 addresses issues beyond body size that are relevant when developing tools. Some areas do not apply to surface operations and are only relevant for microgravity EVA, but there are constraints discussed relevant to both: strength, muscular endurance, and deconditioning.

- First, the MSIS defines strength as "the ability to generate muscular tension and to apply it to an external object through the skeletal lever system." The upper limit of a person's strength can only be sustained for seconds (Man-systems, 1995). The range of strength of both the weakest and strongest crew members needs consideration in design phases. The weakest member needs to be able to operate the equipment, but the strongest member should not be able to damage or break the equipment accidentally.

- Second, muscular endurance can encompass both "the duration a submaximal force may be held in a fixed position (Isometric)" and "the number of times a movement requiring a submaximal force may be repeated (Isotonic)" (Man-systems, 1995). Both are important to tool designs, especially those tools that will need to be held or carried for an extended period of time or those that, like the tongs, require the same repeated motion to open the tines to grasp an object.
- Finally, deconditioning due to time in microgravity affects both aerobic power and strength predominately in the antigravity muscles (Man-systems, 1995). Geology tools rely greatly on the upper body to operate but strength in the legs and lower back are also important for the sample collection. Deconditioning will be a greater factor for some missions over others depending on the amount of time in microgravity and the gravitational force experienced once on the planetary body. However, long term stays in reduced gravity have never occurred so there are no in situ observations for this.

Section 11 covers hardware and equipment including tools. This section is not devoted to EVA, but there are still mentions of EVA requirements that are relevant to surface operations.

- Tools that are to be used during EVA should have "gripping surfaces" on handles that do negligible harm to EVA gloves from rubbing against the surface.
- The handles of tools should allow the operator to apply force while maintaining a natural wrist position.
- Controls should not be able to be activated without intent.
- Tools should be operable with only one hand where possible.

- Handles should not have a handedness preference and should be usable with either the left or right hand.
- The force required by hand tools shall be less than 20 lbs (89N).
- Tools that are "plier-type" in design "shall be spring actuated in the open direction to permit one-handed operation" (Man-systems, 1995).

Section 14 deals with topics related to EVA. There is an explicit reference to reduced gravity EVA stating that there are advantages and disadvantages to suited operations when microgravity and reduced gravity are compared. One factor in decreased efficiency in any suited performance of assigned duties would be "poor... tool design" (Man-systems, 1995).

Tool design must either prevent the possibility of sharp edges or protrusions or provide for their coverage. If a piece of equipment could cause harm to a crewmember on EVA or destruction of EVA paraphernalia "by entrapment, snagging, tearing, puncturing, cutting, burning, or abrading [the equipment] shall be designed to ensure elimination of, or protection from, the hazard." Any tool design should be tested by a representative group of people to ensure that the tools can be operated as expected by all. This should include testing within the expected pressure suit so that "[d]esign forces required for operation of hardware shall not exceed the capabilities of the potential population...". Suited operations also have modified capabilities in joint movement, which affects the reach envelope as does the use of one or two hands for a task. (Man-systems, 1995).

NASA-STD-3001

The NASA-STD-3001: NASA Space Flight Human-System Standard is divided into two volumes covering both human and hardware requirements for manned

spaceflight. Both state within their bodies of text that "[t]his Standard establishes requirements... but does not supersede nor waive established Agency requirements found in other documentation" (NASA SFHSS Volume 1, 2015; NASA SFHSS Volume 2, 2015). The following review of the NASA-STD-3001 primarily focuses on Volume 2 as that contains the sections relevant to tools in "all mission phases (including extravehicular activity (EVA)) [and] all gravity environments..." (NASA SFHSS Volume 2, 2015).

The first volume deals with Crew Health and "establishes requirements to protect the health and safety of crew and to provide health and medical programs for crewmembers during all phases of space flight". It was initially approved in 2007 and was last revised in 2015. Topics include standards for "fitness for duty, space flight permissible exposure limits, permissible outcome limits, levels of medical care, medical diagnosis, intervention, treatment and care, and countermeasures". These prerequisites for flight and planetary habitation are not all in their complete forms and some still need to be developed further for crew safety (NASA SFHSS Volume 1, 2015).

The second volume, "Human Factors, Habitability, and Environmental Health", considers human abilities and how these must affect the interfaces a crew will work with in space and "focuses on human physical and cognitive capabilities and limitations and defines standards for spacecraft (including orbiters, habitats, and suits), internal environments, facilities, payloads, and related equipment, hardware, and software systems with which the crew interfaces during space operations." This volume also references other documents that can be suitable for guidance with other various covered

subjects. It was initially approved in 2011 and most recently revised in 2015. (NASA SFHSS Volume 2, 2015).

The following statements govern all "hardware and equipment" design that the crew interfaces with.

- Range of motion, reach, and strength data will be used as "developed in accordance with section 4.1". Section 4.1 essentially says that any data sets will be developed with the entire population of crew members considered in all measurements and characteristics.
- "The effects of muscle endurance and fatigue shall be factored into system design."
- Equipment design will be such that any tool will be useable with the "lowest anticipated strength."
- All designs will safeguard crewmembers "from entrapment (tangles, snags, catches, etc.)."
- Equipment that is both "fixed and handheld" will have their edges and corners rounded to specifications. While the rationale for this requirement does say that sharp edges and corners could cause damage to EVA suits and be dangerous in EVA situations, "[t]his requirement applies to bare skin."
- "Pinch points shall be covered or otherwise prevented from causing injury to the crew."
- Equipment intended to be transported by hand will be designed with "a means for grasping, handling, and carrying (and, where appropriate, by a gloved hand)."

- The Operations section has not yet been addressed (NASA SFHSS Volume 2, 2015).

JSC-0808-2A

JSC-0808-2A, JSC Design and Procedural Standards, had its origins around 1964 as bulletins which were combined into document JSCM 8080 in 1971. This document was amended in 1991, 2005 and most recently in 2015 when it was re-designated JSC-0808-2A. It is comprised of "design and procedural requirements for human spaceflight equipment based on lessons learned and best practices." These requirements may be enforced for a project in their entirety or as individual requirements. "These requirements are appropriate for the acquisition, design, development, test, evaluation, operation, and sustaining engineering of any human spaceflight program, project, spacecraft, system, or end item" (JSC, 2015).

Most of the relevant requirements for EVA tool design are under the "General" heading. For example:

- During design the functional thermal environment of the hardware, both hot and cold, will be accounted for and hardware "shall be designed to function" in both.
- "Where possible, actuating devices shall be made an integral part of the equipment to be operated. Detachable actuating tools, such as handles, pins, and ratchets, shall not be permitted in applications where tool nonavailability could compromise crew safety or primary mission objectives" (JSC, 2015).

JSC-26626A

JSC-26626A: Extravehicular Activity (EVA) Hardware Generic Design Requirements Document (GDRD) was released in 1995. This document supersedes

NASA-STD-3000. Its purpose is to institute the "design and verification requirements" of tools intended for EVA use. It applies to designs utilized "in the external environment of low earth orbit" and "development of general purpose EVA hardware". However, the document can accommodate "special purpose EVA hardware with unique requirements" (Extravehicular, 1995).

The requirements considered most relevant to the modifications tested in this study:

- Edges and corners that are "exposed" shall follow the standards as stated in Figure 27. "A 45° chamfer with a resulting radius of 0.06 inch is also acceptable with a minimum flat of 0.5 inch."

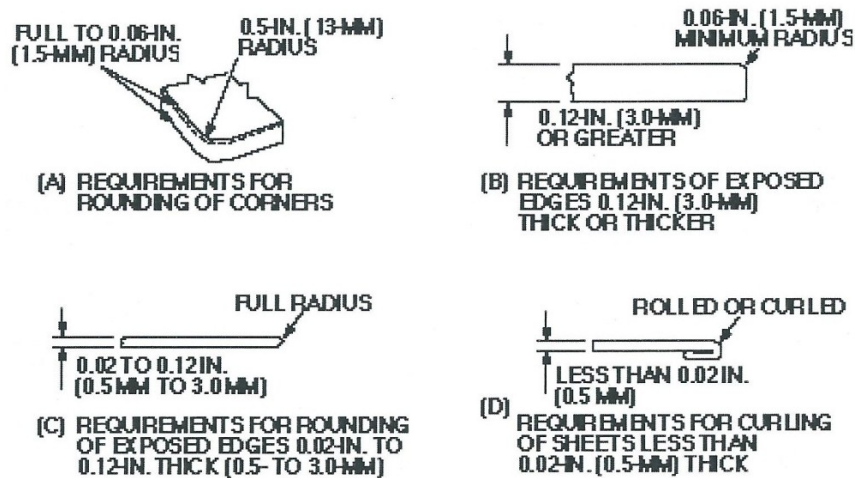

Figure 27. "Exposed Corner and Edge Requirements" (Extravehicular, 1995).

- Hardware will have a "shelf/storage life of 10 years." This time factors in the interval which hardware may be kept "under controlled conditions" from which the hardware can be taken and utilized without any maintenance "beyond routine servicing."
- "The structure shall possess sufficient strength, rigidity, and other necessary physical characteristics required to survive design conditions specified herein."

- a. Consistent with the structural design principles listed herein, the structure shall be designed to achieve minimum weight wherever practicable.
 - b. The effects of allowable structural misalignments and other permissible and expected dimensional tolerances shall be considered in the analysis of all loads, load distributions, and structural adequacy.
 - c. The effects of repeated loads will be considered in the structural design.
The design structural adequacy of the EVA hardware shall not be impaired by fatigue damage resulting from exposure to flight as well as non-flight environments.
 - d. The environmental phenomena corresponding to each design condition shall include all factors that can influence the EVA hardware structural design and typically including heating, vibration, acoustic noise, and shock in addition to quasi-static and dynamic loads."
- "All devices shall be designed and/or shielded in a manner that does not allow gaps or overhangs and precludes sharp edge and/or pinch hazards which could potentially damage the EMU [Extravehicular Mobility Unit]."
 - "Actuation forces shall not exceed 20 lb (89 N) for hand tools and other hardware items which require repetitive/continuous operation."
 - "The actuation of hardware designed for finger operation shall be 2 to 10 lb (9 to 44 N)."
 - "Hand gripping surfaces shall incorporate a non-slip surface and prevent abrasions to the EVA glove material. Note: This requirement applies to items with repetitive use potential."

- "Hand tools shall be capable of one-handed, ambidextrous, engagement, disengagement, and operation."
- "Pliers-type tools shall be spring actuated in the open direction to permit one-handed operation" (Extravehicular, 1995).

NASA/SP-2010-3407

NASA/SP-2010-3407: Human Integration Design Handbook (HIDH) has the purpose of being "a resource for implementing the requirements in the SFHSS [Space Flight Human-System Standard, NASA-STD-3001], and it provides the data and guidance necessary to derive and implement program-specific requirements that are in compliance with the SFHSS." This document is to cover any operations by a crew including both intravehicular and extravehicular activities both in open space and on "lunar and planetary surfaces." It was first released in 2010 and was last revised in 2014 (HIDH, 2014).

Choosing user population is important due to its universal affect on spacecraft and equipment. User population is affected by a number of factors and should consider "age, gender, ethnicity, and other special considerations" such as degree of physical fitness. Also, change in population over time may be an important aspect in determining user population if the design is for equipment to be used in the distant future. The range of user population as defined in the NASA-STD-3000 was found to omit too many anthropomorphic characteristics and therefore "a broader range of user population must be considered" if regulations for selection are unchanged (HIDH, 2014).

Once the characteristics of the users are determined, equipment and system design must accommodate them. The three options for designs that can be used by a varied crew

are "single solution for all", "adjustment", and "several solutions". These are the same methods that are offered in NASA-STD-3000 and necessitate obtaining and utilizing suitable "anthropometric, biomechanics, and strength data." These data must also account for whether the appropriate measure is taken for shirtsleeve crewmembers or for suited crewmembers. If the activities are for suited individuals, consideration must be given to whether the operations will be performed with the suit fully pressurized, ventilated, or either/both, as specific suits and suit statuses will affect anthropometry differently. The gravity conditions of the crewmember must also be considered as this can affect characteristics such as height. However, "though additional postural effects may be present due to partial gravity, this has not yet been quantified and therefore is not addressed." Thus, more data on changes in anthropomorphic characteristics in "partial gravity (1/6 and 3/8)" are needed (HIDH, 2014).

EVA equipment is held to the standards of two sections of the HIDH: Chapter 9 "Hardware and Equipment" and Chapter 11 "EVA". Hardware design should incorporate human factors to "enhance crew performance, safety, and comfort during operations" (HIDH, 2014). The following list contains a representation of these requirements.

- Equipment design should be safe and afford "safe and efficient use, manipulation, and handling."
- Designs should be robust and dependable and able to "[withstand] the forces imposed intentionally and unintentionally by crewmembers and capable of sustaining operations for extended durations with minimal maintenance."
- Equipment should be designed for use by the entire range of crew anthropomorphic characteristics, strength, and range of motion (HIDH, 2014).

A selection of tool design requirements follows:

- For EVA tools, the "grip surface" should accommodate the glove of the EVA suit to be worn. In addition, the surface on the EVA tool handle must " minimize abrasion to EVA glove material."
- The handle should permit use while the wrist is in its most natural attitude when "force or guidance inputs are applied."
- Tools should be equally functional for crewmembers of right or left-handedness and should be useable with a single hand where possible.
- The actuation force of a tool needs to be "less than the strength capabilities of the crew".
- Tools should not be able to be disassembled accidentally "while installing, using, removing, or transporting the tool."
- All tools should have a method of restraint for "0g conditions" (HIDH, 2014).

This last point would seem to suggest that this document assumes all tools will be used in micro or zero gravity and that no tools would be developed exclusively for use in a reduced gravity environment such as the lunar surface.

The following section from Chapter 11 is specifically for EVA. An EVA is defined as "any activity performed by a pressure-suited crewmember in unpressurized environments internal or external to space flight habitable modules, in space environments, or in extraterrestrial environments with atmospheres unable to support human life." Suited performance is affected by a number of factors, including the internal pressure. "The current suit used on the ISS, the ... EMU, operates at 4.3 psi total pressure. These factors can decrease "mobility and dexterity, force application, and endurance". In

order to advance the capabilities of crewmembers suited for EVA "visual performance, reach, range of motion, strength, and mobility" must be improved. While suited, the reach of a crewmember is changed and EVA tasks and procedures should not call upon a crewmember to "approach the limits of reach" (HIDH, 2014).

Suit designs change with intended purpose and working environment; planetary suits need to function differently than suits intended for microgravity or 0g. In such an environment, the legs and feet become important and must accommodate "walking, hopping, and performing weight-bearing tasks" to allow for safe carriage across terrain, both flat and irregular, and possibly climbing ladders. Also, "kneeling to collect surface samples should be considered." "Controls that will be operated by a pressure-suited crewmember must accommodate limited finger and hand range of motion and dexterity" (HIDH, 2014).

The issue of gripping objects and hand strength while suited is a complex problem that both EVA glove designers and EVA tool engineers must consider. Moving fingers and hands within a pressurized glove takes noticeable effort. This is especially apparent with repetitive motion and continuous gripping. The repetitive nature of some tasks can be partially alleviated by glove design or the design of the interface between the object and the glove itself (HIDH, 2014).

NASA/TP-2014-218556

NASA/TP-2014-218556: Human Integration Design Process (HIDP) was released in 2014. Its purpose is to expand upon the implementation of NASA-STD-3001, but "can be applied to any set of human-systems requirements." There are four central concepts to human-centered design: "[a]ctive involvement of users and a clear understanding of user

and task requirements, [f]unction allocation between users and technology, [d]esign iteration, [and m]ultidisciplinary design" (HIDP, 2014).

NASA/TM-2007-214755

NASA/TM-2007-214755, The Apollo Medical Operations Project: Recommendations to Improve Crew Health and Performance for Future Exploration Missions and Lunar Surface Operation, is a document that was researched and assembled to record the opinions of Apollo astronauts on "the impact of the Apollo vehicles, hardware, and systems on crew health [and] performance throughout all mission phases, including lunar surface operations and the influence of that impact on the new exploration vehicles and mission architectures." It includes historical research into previous observations made by Apollo astronauts which were then used as a basis for discussion topics covered during a summit and in post-summit correspondence. In total, considering both summit and post-summit participation, fourteen Apollo astronauts contributed of a potential twenty-two. One of the fourteen category topics covered was lunar surface operations. This paper is included because recommendations from the summit and post-summit questions and discussions are in various stages of consideration for inclusion in future requirements (NASA, 2007).

From the gathered crew data, "the most fatiguing part of surface EVA tasks was repetitive gripping." This is discussed as part of the EVA suit category and the astronauts comments appeared to imply that this was due more to the glove design or suit pressure than from the design of the surface tools (NASA, 2007).

In a panel discussion, hand fatigue was again given attention, reiterating the problem of "requiring finger dexterity", referencing maintaining a continuous hold on an

object, such as a hammer. When grip fatigue came up in a later question and forearm fatigue was indicated, "[t]he crewmembers were unable to specify cause of problem." The idea of working on forearm strength was discussed separately, but an observation in the comments was that "operating the surface tools in partial gravity, particularly the drill, requires more force generated from the shoulders than needed in 1 g." A mention was made that kneeling would be done more often if the suit possessed greater flexibility (NASA, 2007).

The paper also references recommendations from the various Apollo Medical Mission Debriefs. One of the observations was "[d]o not re-design lunar tools. They worked for the jobs that had to be performed". This comment is not cited to a particular mission and it should be noted that the medical debriefs are "considered medically confidential material and subject to the Medical Privacy Act of 1974"(NASA, 2007). Due to this, these documents are not referred to in this thesis.

CHAPTER III

STATEMENT OF PROBLEM

Reduced gravity, planetary exploration has not been performed by humans since the lunar landings of the Apollo program. Future astronauts will have scientific objectives to accomplish just as their Apollo counterparts did, including collecting data and samples with regard to planetary geology. Since such operations have only been relevant for the manned lunar landings, the tools for reduced gravity, geology collection have not been a main focus of tool development. The focus has been more concentrated on microgravity EVA tool development.

This research is looking forward to answer some specific questions for the next steps in space exploration as outlined by the NASA Authorization Act of 2010 and NASA's declared plan for future manned planetary missions (NASA's Journey to Mars, 2015). EVA tool design is integral to human exploration of planetary bodies. A determination needs to be made whether hardware can be improved for different tasks so they may be performed efficiently and with the least physical strain and fatigue.

CHAPTER IV

HYPOTHESIS

Modifications that increase the grip diameters of geologic sampling hand tool replicas will significantly improve performance of geologic sampling tasks.

The greatest improvement in performance will occur with tool configurations featuring increased diameters of all modified grips.

CHAPTER V

METHODOLOGY

Tool Selection

Many geology tools were flown during the Apollo lunar landing missions. Each had a purpose at the time, but all were not equally relevant in the long term. Some tools changed during their flight history to address reported issues, while others remained static for different reasons, e.g., adequate original design, time constraints, only flown on a single mission. Multiple factors were considered when deciding on the tools that would benefit most from a redesign: planetary geology, what is known and what data are important to future planetary research, the purpose and history of the geology tools, as well as the interfaces between human, space suit, and equipment.

All these factors led to the development of selection criteria to designate the tools for this study. First, the chosen tools needed to still be in use at the end of the Apollo lunar landings. This was to ensure the tools modified for the test were still relevant and had not been replaced or deemed extraneous. Second, the tools needed to be used for general geological sample collection, which precluded any tools designed for a specific experiment. Third, the tools needed to be used while the astronaut was on the surface. For example, tools intended to be used from a rover would need to be redesigned based on rover specifications as well as human needs. Such modifications would require a specific rover design and such future designs could negate the ability to sample from within the

rover using hand tools. Finally, the tools needed to have characteristics capable of being tested at the chosen research site.

Ultimately the tools selected were the large-adjustable scoop, 32-inch tongs, and rake. They were made according to specifications obtained from the archives at NASA's Johnson Space Center (JSC). The material selection does vary some from the lunar tools themselves due to the need for the tools to be durable enough to repeatedly pick up and work with material in terrestrial gravity as opposed to reduced lunar gravity. The two materials used were 4130 steel and 6061 T6 aluminum. The scoop and rake are also made with permanent handles instead of requiring the attachment and detachment of the extension handle.

Two versions of the tongs were taken to the testing site, but only one was used. The pair of tongs tested was provided by NASA's JSC. These tongs were also built to Apollo era specifications with the exception of the attachment of the tines. The original plans call for these to be welded to their structure and the version tested had the tines bolted on.

Tool Modification

It was determined that a complete redesign of the tools would make any improvements or detriments in performance difficult to trace back to the corresponding modification. This led to alteration of only the diameter of the tool handles; the lengths remained unaltered. Casings were made for the handles that could easily be mounted and removed during the experiment. Both the rake and the scoop had two handles modified during the test. The first fit over the crossbar of the t-handle and the second fit over the shaft. The tongs only had the top handle modified due to the manner in which it was

used, typically one-handed, and its mechanics. The original and modified handle diameters are listed in Table 1.

Table 1. Tool measurements.

Tool	Original T-Handle Diameter		Modified T-Handle Diameter		Original Shaft Diameter		Modified Shaft Diameter	
	Inches	cm	Inches	cm	Inches	cm	Inches	cm
Rake	0.50	1.27	1.15	2.93	0.75	1.91	1.11	2.85
Scoop	0.50	1.26	1.07	2.70	0.75	1.90	1.08	2.71
Tongs	0.73	1.85	1.06	2.71	NA	NA	NA	NA

The handle casings were made of ¾ inch PVC pipe (internal diameter) with a thickness ranging between .116 to .131 inches (2.91-3.20 mm). This material was chosen for its uniformity, durability, rigidity, smooth surface, minimal addition of mass, the ease of modification, and the ability to be used on all necessary tool handles. The casings for the shafts of the scoop and rake were PVC pipe cut into two pieces lengthwise which were then attached using Velcro. The t-handle covers were all made to slide over their respective handles. The scoop casing was secured on the far side with a screw cap while the rake and scoop casings were secured by Velcro. All of the handles had foam in them to ensure a snug fit over the original handle and to decrease the movement of the casing while the tool was in use.

Suit

The North Dakota Experimental 1 (NDX-1) Planetary Suit was designed to be used during planetary surface analog EVA, Figure 28. It is intended to allow for greater mobility during exploration, Figure 29, and to minimize the contamination and thermal impacts that would be experienced on extraterrestrial surfaces.

The NDX-1 was designed to be a pressurized planetary exploration suit. It is a mid-level entry suit comprised of two parts: the torso, constructed of soft components



Figure 28. NDX-1 Planetary Suit.



Figure 29. Demonstration of NDX-1 suit flexibility
{Credit: NASA-JSC: Larry K. Dungan}.

attached to a hard upper torso, and the soft pants. The two pieces are joined in the middle using clamps. The soft portions of the outer/restraint layer of the suit are comprised of a Kevlar material with nylon banding and hard components are constructed of carbon fiber with Nomex® core material. The inner bladder is made of neoprene coated nylon and is removable for repair or replacement and the gloves are neoprene with cuffs coated in natural latex. The NDX-1 is designed to accommodate a range of heights and limb lengths through lacing in multiple places, with torso length being more restrictive due to the hard component. The helmet is made of carbon fiber with a similar structure to the upper torso, differing by the use of Nomex® core material in key places and not throughout the entire structure, and has a fixed visor made of Plexiglass®. Steel pegs attach the helmet to the hard upper torso at the neck ring.

The life support system was by umbilical for this study, with the pressure differential in the suit never exceeding 3.5 psi to ensure the safety of the occupant. Communications were accomplished through cabled headsets and a control box allowing for contact between the subject and multiple members of the study staff. The suit has the ability to be worn with a liquid cooling garment (LCG), but the LCG was deemed unnecessary for this study.

Prior to this study, the NDX-1 was tested in multiple controlled and natural environments. Field testing that executed simulated EVA tasks was performed for a week in the Badlands of North Dakota. The next test was performed at the Mars Desert Research Station (MDRS) in Utah where field testing could be done with a habitat for variation in EVA tasks. The third field test was done at the Marambio Base in Antarctica where different equipment was tested. The last field test was performed in the Pilbara region of Australia and executed EVA tasks, as well as tested perception of surroundings while operating within a space suit and helmet. This suit has also been tested in a controlled environment to determine dust contamination.

Location

Testing was performed at NASA's KSC in the Regolith Bin operated by Swamp Works, see Figure 30. It contains approximately 120 tons of regolith simulant and has a surface area of approximately 24 x 25 feet [7.3 x 7.6 m] and a height of 18 feet [5.5 m] with 42 inches [1.1 m] of regolith, Figure 31. The Don/Doff area is approximately 10 x 6 feet [3.0 x 1.8 m] (J. Beardall, personal communication, March 10, 2016), see Figure 32. The facility is climate controlled. Testing can be viewed from outside the regolith bin as

the walls are made of lexane. This was the first time a suited test has taken place at the regolith bin.



Figure 30. Regolith bin, Swamp Works NASA KSC {Credit: NASA-JSC: Larry K. Dungan}.



Figure 31. View through regolith bin.

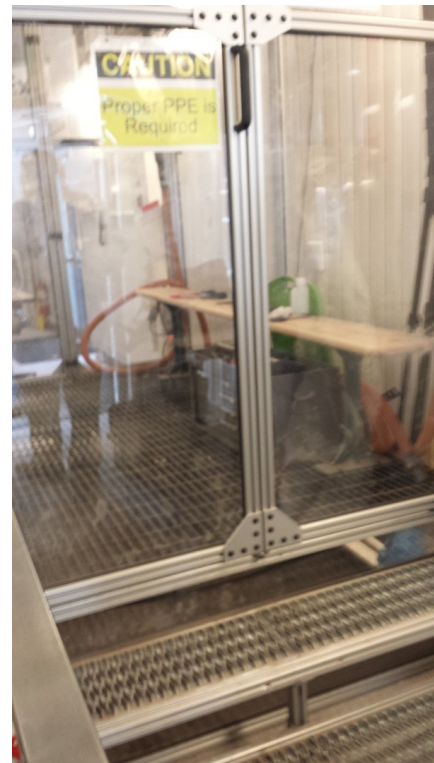

Figure 32. Regolith bin airlock and Don/Doff area.

This experiment was, in part, built around the opportunity presented to the UND's Human Spaceflight Laboratory to bring one of its space suits to NASA's KSC to test the feasibility of performing fully pressurized, suited operations within the regolith bin. The test needed to be of such a design that the use of the regolith bin would increase the fidelity or at least better inform the study with the physical characteristics of the simulant. This study was then adapted to work within the confines of the regolith bin and in the time allotted for the testing.

Regolith Simulant

The regolith simulant was BP-1 (Black Point 1) Lunar Regolith Simulant, Figure 33. BP-1 comes from a rock quarry in northern Arizona and consists of "Black Point basalt flow and silt-sized washing paste" (Suescun-Florez et al., 2015). Suescun-Florez, Roslyakov, Iskander, and Baamer (2015), studied BP-1 and compared it with other simulants and lunar regolith geotechnical properties, e.g., granular size distribution, specific gravity, shear strength, see Figure 34. They concluded that "available geotechnical properties of BP-1 are consistent with those of lunar regolith and other regolith simulants" (Suescun-Florez et al., 2015).



Figure 33. BP-1 Lunar Regolith Simulant (Suescun-Florez et al., 2015).

Soil	G_s	ρ_{\min} (g/cm ³)	ρ_{\max} (g/cm ³)	Source
BP-1	2.81	1.43	1.86	This study
GRC-3	2.63	1.52	1.94	He et al. (2013)
JSC-1	2.90	1.33	1.80	Willman et al. (1995), Perkins and Madson (1996)
JSC-1A	2.88	1.57	2.03	Zeng et al. (2010)
MLS-1	3.20	1.56	2.20	Weiblen and Gordon (1988); Perkins and Madson (1996)
Lunar regolith	2.90-3.24 ^a	0.87-1.36 ^a	1.51-1.93 ^a	Carrier et al. (1973)

Note: For comparison purposes only; testing methods and standards may vary for different soils.
^aResults from different lunar missions.

Figure 34. Table of minimum and maximum densities of Lunar regolith and assorted regolith simulants (Suescun-Florez et al., 2015).

An initial test run with the suit and tools was performed prior to reaching KSC. This dry run used sand bought from a hardware store for a regolith simulant substitute and was to help determine timing and set-up. Differences in the interactions between the tools and the material were found when observations were compared between the preliminary test run to the testing at the regolith bin. Subject 1 reported in the post-test questionnaire that there was a vacuum-like effect on the scoop while collecting simulant during the scoop regolith test, an observation not made by the suited participant in the sand test. The simulant also had a greater resistance to tools attempting to penetrate deeper into the simulant, especially in areas where the regolith had been compacted.

Experiment

Experiment Design

This experiment was composed of four different tests: two involving the scoop, one with the rake, and one for the tongs. All four of these tests are two-factor experiments: suited/unsuited condition and tool configuration. Unsuited/suited condition had two levels; Two subjects engaged in both unsuited and suited operations. The number of levels with the number of configuration changes depended on the tool. The scoop and rake had five levels and the tongs had three; see Table 2 for a listing of configurations. Each set of conditions had three replicates.

Target size was also an independent variable used during three of the tests. The scoop target, rake, and tongs test each had a standard combination of target sizes that were randomly distributed in the target area. This variation in target size was done to help ensure that the full range of the tools were tested and to decrease the potential of any one target size skewing a tool's results. Tools were tested in their original configuration

before and after the modifications to observe subject changes in performance due to factors such as learning and fatigue. Handle modifications were tested separately and then together to help permit the traceability of any performance changes to the contributing factor or factors.

Table 2. List of tested tool modifications in order performed.

Tool	Configuration	Description	Figure
Scoop	1a	No handle modifications	35
	2	T-handle modified	
	3	Shaft modified	
	4	T-handle and shaft modified	
	1b	No handle modifications	
Rake	1a	No handle modifications	36
	2	T-handle modified	
	3	Shaft modified	
	4	T-handle and shaft modified	
	1b	No handle modifications	
Tongs	1a	No handle modifications	37
	2	T-handle modified	
	1b	No handle modifications	



Figure 35. Scoop configurations.



Figure 36. Rake configurations.

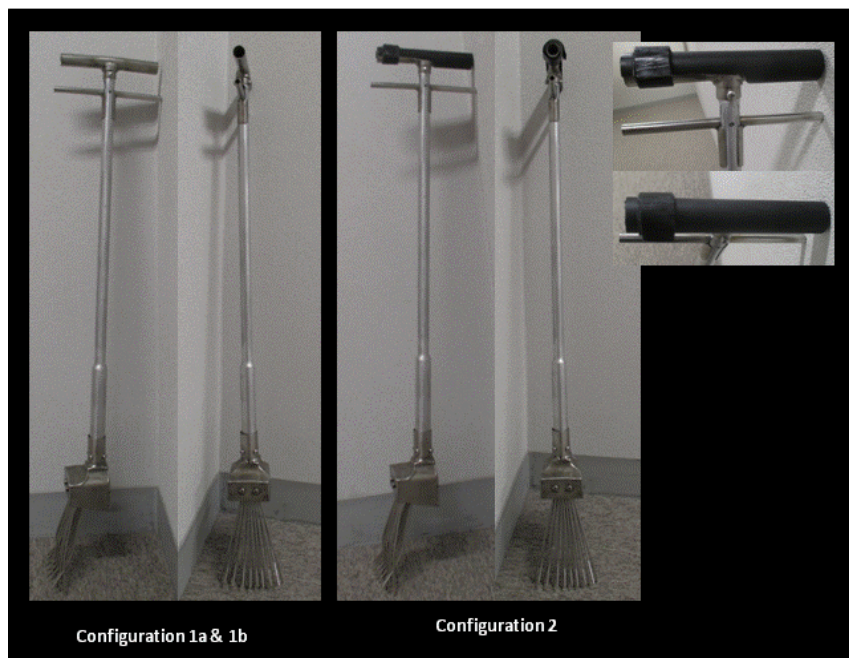

Figure 37. Tong configurations shown with UND's tongs not those on loan from JSC.

Test Subjects

Due to the human involvement during testing this study was approved by the University of North Dakota's Institutional Review Board through the expedited review process, IRB project number IRB-201510-106. Test subjects were informed of their rights and any dangers of the testing and gave their consent to be part of the study. Safety

precautions were taken as they were set out in the IRB documentation. These included: keeping a spare mask accessible to all study staff during suited testing in case the subject's helmet had to be removed; every individual to enter the bin had to be wearing appropriate personal protective equipment (PPE) including respirators; air being pumped to the suit was required to pass through an OSHA approved filter; verbal communication and line of sight observation with the subject was maintained at all times; and the compressor used to pressurize the suit was constantly monitored by study staff who were in the communications loop.

Two subjects participated in this study. Both were male and their respective anthropomorphic measurements can be found in Table 3, illustrations of these measurements from NASA-STD-3000 can be found in Appendix B. Both subjects had experience in NDX-1 operations prior to the start of the testing, as well as experience with other suits. One subject was left-handed and one subject was right-handed.

Table 3. Subjects' Anthropomorphic Measurements.

Anthropomorphic Measurements	MSIS Number	Subject 1 Centimeters	Subject 2 Centimeters
Stature	805	180	177.0
Wrist Height	973	85.0	91.0
Elbow Height	309	113.0	115.0
Popliteal Height	678	52.5	47.5
Shoulder-elbow Height	751	39.0	36.0
Buttock-knee Length	194	53.5	45.0
Hand Length	420	19.0	19.0
Hand Breadth	411	8.5	9.5
Acromial (Shoulder) Height	23	145.0	149.5
Trochanteric Height	894	97.5	96.0
Tibiale Height	873	50.0	48.0
Thumb-tip Reach	67	69.0	69.0
Waist Height	949	113.0	107.0

Layout

The experiment set-up included three, 1 square meter sections cordoned off within the regolith bin using stakes and flagging tape. Two sides of the squares were left open to minimize the chance of subjects and tools becoming entangled in the boundary markings. All targets were spheres to ensure uniformity of target-tool interactions between runs and between subjects. The target sizes used depended on the tool being tested and were chosen to reflect the tools original intent and design capabilities. Spheres of identical size were painted the same color so target size could be determined in images and video, see Table 4, Table 5, and Figure 38 for target sizes.

Table 4. Target sizes according to manufacturer.

Color	Diameter		Color	Diameter	
	Inches	Centimeters		Inches	Centimeters
Purple	1.0	2.5	Black	3.0	7.6
Yellow	1.5	3.8	Red	4.0	10.2
Orange	2.0	5.1	Dark Blue	5.0	12.7
Light Blue	2.5	6.4	Green	6.0	15.2

Table 5. Target size; purple through black measured directly, red through green calculated.

Color	Diameter		Color	Diameter	
	Inches	Centimeters		Inches	Centimeters
Purple	0.99	2.53	Black	3.01	7.64
Yellow	1.49	3.78	Red	4.14	10.52
Orange	1.98	5.02	Dark Blue	4.89	12.42
Light Blue	2.48	6.29	Green	5.97	15.16

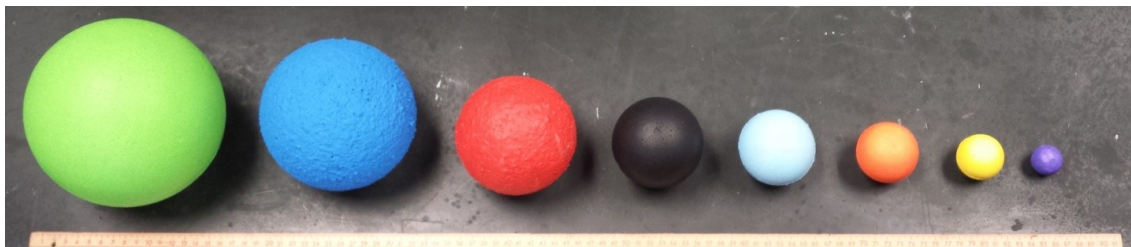

Figure 38. Targets arranged by diameter.

All set-ups are shown in Figure 39. The first test of the scoop focused on the retrieval of individual targets. Ten targets of 1, 1.5, and 2 inches in diameter were placed in every designated test area, for a total of thirty targets in an area. Twenty containers with a top diameter of 4.11 inches (10.44 cm) were placed along an outside edge of each target area. Within each container a labeled plastic zip top bag was placed to capture the excess regolith. The scoop regolith test used no targets, but had a plastic bin measuring 10.5 x 13.5 inches (26.7 x 34.3 cm) at the top placed outside the demarcated test area. A labeled large plastic bag was placed within each bin to collect the regolith. A set of thirty



Figure 39. Experimental set-ups, top-left rotating clock-wise; scoop target test, rake test, tongs test {Credit: NASA-JSC: Larry K. Dungan}, scoop regolith test.

targets was also placed randomly within each of the 1 square meter areas for the rake test.

A set contained six different target sizes with five sizes of each in any one test area: 1,

1.5, 2, 2.5, 3, and 4 inches. The rake test also used the 10.5 x 13.5 inches (26.7 x 34.3

cm) plastic bins. The test of the tongs also had thirty targets in each test area: three of 1 inch, two of 1.5 inches, two of 2 inches, two of 2.5 inches, five of 3 inches, five of 4 inches, six of 5 inches, and five of 6 inches. Subjects were instructed to pick up an individual target and then place it in either a small container of 4.11 inches (10.44 cm) in diameter or a large container of 10.5 x 13.5 inches (26.7 x 34.3 cm) depending on their assessment of which container would be most appropriate for the target diameter.

Procedure

The procedure was designed in such a way to help mitigate, or at least detect, the factors of learning and fatigue. First, both participants were given the same amount of training prior to their testing. During training, subjects were instructed on how to perform their assigned tasks including the methods in which the tools should be used and an explanation of the tasks they were to execute. Second, the tool testing order was identical for both subjects. This created an option for comparing subjects against each other across time, since subjects were anticipated to have similar amounts of fatigue and learning at corresponding times during the experiment. Finally, extended breaks were kept at the same time during the experiment. Variations in timing could be due to suit donning time, differences in set-up time, and breaks requested by the subjects. Tests were performed unsuited and then suited.

The scoop, Figure 40, had two functions tested. Both followed the handle modifications as outlined in the configuration listing in Table 2. Each of the listed configurations had three runs unsuited and three runs suited. The first scoop test dealt with the ability of the scoop to pick up individual targets by counting the number of targets collected in one minute and recording the number of collection attempts, drops,



Figure 40. Scoop.

and times the sample containers were missed. Subjects were instructed to pick up one target at a time with as little regolith as possible. Targets were retrieved with the scoop at a 45° degree angle and placed in containers. The excess regolith was captured in bags that were later weighed. The second scoop test was designed to determine how much regolith could be scooped in thirty seconds with the scoop at a 45° angle. Subjects were instructed to shovel regolith for thirty seconds and to retain all the regolith scooped without spilling material between the collection site and the container. The mass of collected regolith was later weighed.

The number of targets collected and dropped was employed as a measurement of usability that could easily be compared across configurations. Sample containers being missed was a measure of accuracy, e.g., whether the scoop allowed for enough control to place a target in a relatively small container, and precision, e.g., did the scoop perform this task with any predictability. The number of collection attempts and the amount of incidental regolith collected with the targets was used as a measure of accuracy; how much regolith did the subject need to gather with the target to retrieve it. A smaller amount of incidental regolith implied higher accuracy. Precision was measured by the consistency of the amount of regolith collected for all targets or for targets of a single diameter. Target color was recorded for each gathered target to determine whether target size contributed to the differences in any of these measures. The simulant gathered during

the regolith scoop test was used as a measure of performance, the instruction to the subjects to be as accurate as possible when placing the accrued material in the collection bin.

The test objective for the rake, Figure 41, was to measure its ability to collect samples. The configurations were tested as outlined in Table 2 with each configuration tested three times unsuited and then three times suited. The rake was tested at a 45° angle. Subjects were instructed to collect targets within the designated areas and to shake out all



Figure 41. Rake Head.

the excess regolith. The subjects were not instructed on how to shake out the excess regolith and ended up using two main methods to accomplish this: shaking the rake in an up and down motion or twisting the rake about an axis through the shaft. The targets were then placed within the nearby container. The number of

targets collected over the thirty second time period was recorded, as well as the number of passes, the number of targets that were dropped (this includes targets that missed the container), and the sizes of all targets collected and dropped.

The number of targets collected was used as a measure of performance for the rake to compare between configurations. The number of passes was also counted as a performance measure for the rake and to complement the data collected on the number of targets gathered. These data allowed for clarification on why the number of targets may have varied other than due to handle modifications, e.g., length of the passes. The count of targets dropped measured the accuracy of the rake to place samples in a container and

whether this characteristic was consistent measuring precision. Target sizes were recorded for the eventuality that they influenced any collected data.

The functionality of the tongs, Figure 42, was tested by collecting individual targets. The handle modification was performed as outlined in Table 2 with each configuration being tested three times unsuited and then suited. Targets were collected



Figure 42. Tongs provided by JSC and used for testing {Credit: NASA-JSC: Anthony D. Hood}.

and then placed in a nearby container. Subjects were instructed to allow the tongs to close entirely around each target. The total number of targets collected in 30 seconds along with the size, collection attempts, drops, and container misses of each target were recorded.

The number of targets collected and the number of drops for any particular target was a measure of performance for the tongs. Accuracy was measured by the number of collection attempts needed to retrieve a particular target and the ability of the tongs to place a target in a collection container, measured by the number of missed containers. These two measures also allowed for a measure of precision by looking at the consistency of the tong's performance. The size of each target was recorded so diameter could be looked at as a contributing factor to the different measures.

Data Capture

Most data were gathered manually in real time on data collection sheets (Appendix C) that included all the counts, i.e., targets collected, targets dropped, targets missed, collection attempts. After a section of testing was finished, such as Subject 1

unsuited, the regolith from the scoop target test was weighed in grams on a digital lab scale, Figure 43, and regolith from the scoop regolith test was weighed in kilograms on a larger digital lab scale provided by Swamp Works, Figure 44. These numbers were also recorded manually on data collection sheets. Portions of the test were video recorded



Figure 43. Set-up for small lab scale measurements.



Figure 44. Large lab scale and speakers.

using two stationary Gopro cameras and, during suited portions of the test, another Gopro camera mounted on the helmet of the NDX-1. Portions of the audio loop were recorded via a wireless transmitter that sent the signal to a receiver attached to speakers, Figure 44, outside the regolith bin and then to a digital recorder. During testing subjects were free to remark on the tool functioning and were sometimes asked to respond to questions from the study coordinator. After the testing was finished, subjects were given a brief questionnaire asking them to compare and contrast the use of the tools in their different configurations.

Statistical Method

The gathered data were later entered into Minitab 17 by hand. The data were examined both by individual subject data and combined subject data. Comparisons were made within these data sets between tool configurations to determine if changes in performance occurred. The time permitted for the study was believed to be generous, but only allowed for two subjects and three runs of any one configuration during a test. This meant that overarching conclusions were unlikely to be made and general trends would be more the scope of this study. Means were used to compare data and significant differences were used to help determine if the variation in the data could have real world relevance. Difference was considered significant if $p < 0.05$. These calculations were done using a 1- sample t test, a 2-sample t test, or a one-way ANOVA test.

CHAPTER VI

RESULTS

General Test Observations

Data collected during this study allowed for the analysis of general trends. More definitive conclusions will require a greater pool of subjects and likely more runs, which scheduling did not allow during this test. The two subjects' data sets were combined for comparisons of the modified configurations to the baseline tools. However, direct comparisons were not made across subjects due to differences in suited experience and their approaches to the task.

The unsuited tests of both subjects were used as a trial run to both familiarize the subjects with the procedure, surroundings, tools, expectations, etc. and for the study staff to practice data collection, procedure, and to observe subjects, i.e., difficulties being had, necessary reminders during testing. Thus the unsuited data for this test are only touched on to demonstrate any possible learning that occurred with the tools and tests for each subject. The suited data are also the focus because the modifications being tested are for EVA tools, the concern is how they operate with suited personnel, not during shirtsleeve operations.

There were some observed differences between the subjects personal approaches to the testing made by the test coordinator. Subject 1 appeared more aware of being observed than of the time allowed and therefore seemed more focused on accuracy than speed. Subject 2 came across as being conscious of the passing time and worked more

quickly to accomplish as much in the time allowed as possible. Whether due to these innate differences or other external factors, there were instances when the statistical analysis presented significant differences that only showed in one subject's data, but not in the combined. The significant differences found in the combined subjects' data are indicated in a table for each test and are the only significant differences discussed in this paper.

Scoop Target Test

This test collected data on number of targets retrieved, incidental regolith collected, number of retrieval attempts, number of targets dropped, and number of times targets missed their intended container. If targets missed the collection container, subjects were instructed not to attempt retrieval, but to continue to place the simulant in the container so the amount of simulant for a target size could be compared without the contamination of the extra regolith or loss of regolith.

Total targets collected for each replicate of all configurations can be seen in Figure 45. The unsuited testing for both Subject 1 and Subject 2, top two frames in the figure, suggests possible learning from Configuration 1a to Configuration 1b, the baseline configuration. The lower half of Figure 45 displays the suited data for both subjects. Subject 1 and Subject 2 appear to remain more consistent within the baseline, Configurations 1a and 1b, suggesting less learning occurred during the suited versus the unsuited portion of the test. There appears to be little variation between modifications as well. During the suited testing the subjects stated that the unmodified handles felt a little too small when used with the gloves. When suited both subjects' perception was that the handle modifications affected the performance of the tools. Subject 1 thought the

increased diameter of the t-handle was more important than that of the shaft, but noted that having both was the preferred configuration. Subject 2 mentioned that the modifications made the repetitiveness of the tasks more effortless. When comparing the

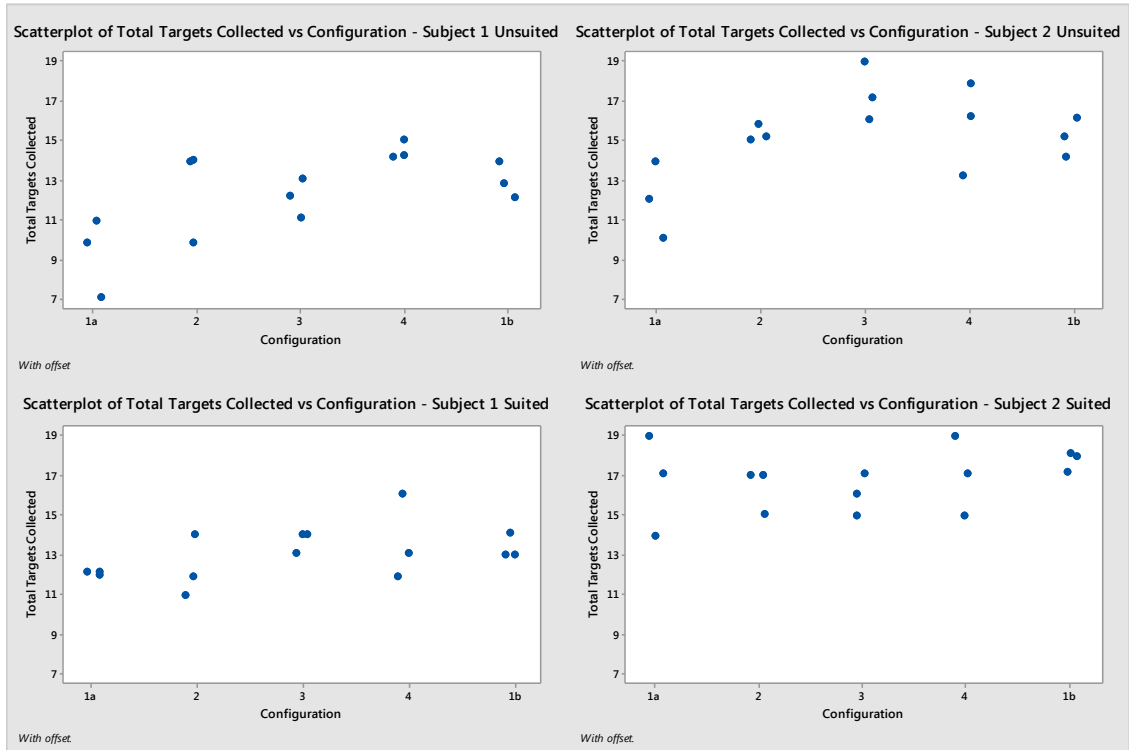

Figure 45. Chart of total targets collected vs. configuration sorted by subject and unsuited/suited.

modifications of the scoop to the baseline, i.e., Configurations 1a and 1b, there were no significant differences found in any of the subjects' suited data: total targets collected, collection attempts, targets dropped, overall incident regolith, or missed containers, Table 6. However, both subjects reported a perceived increase in tool performance when the modifications were used.

When the incidental regolith was analyzed, the data included all three possible target sizes indicated by their color. In order to take a closer look at incidental regolith, the targets collected during suited operations were separated by size and the modifications were again compared against the baseline scoop, Configurations 1a and 1b.

Table 6. Scoop target test data.

	Targets Collected	Collection Attempts	Targets Dropped	Missed Container
Combined Baseline to:	Combined Subject Data			
Config. 2	Not Significant	Not Significant	Significant at $p < 0.10$	Not Significant
Config. 3			Not Significant	
Config. 4				

	Incidental Regolith			
	w/all Targets	w/1.0 inch Targets	w/1.5 inch Targets	w/2.0 inch Targets
Combined Baseline to:	Combined Subject Data			
Config. 2	Not Significant	Not Significant	Not Significant	Significant at $p < 0.05$
Config. 3				Not Significant
Config. 4				

	Incidental Regolith Compared by Target Size (1.0, 1.5, and 2.0 inches)
	Combined Subject Data
Config. 1a/b	Significant at $p < 0.05$
Config. 2	Not Significant
Config. 3	
Config. 4	

Significant difference ($p < 0.05$) between the baseline configuration and Configuration 2, t-handle modified, was found for incidental regolith when 2.0 inch (orange) targets were collected in both the combined subject's data (Figure 46). A decrease in incidental regolith accompanying 2.0 inch targets is found for Configuration 2. While the reality of this improvement is bolstered by being found in the combined data set, its practicality for target collection is still uncertain. Configuration 2 may increase accuracy for one target size, but shows no improvement in the other two sizes tested. Therefore the relevance of this test result may depend on the operational decision of when to use the scoop during sample collection.

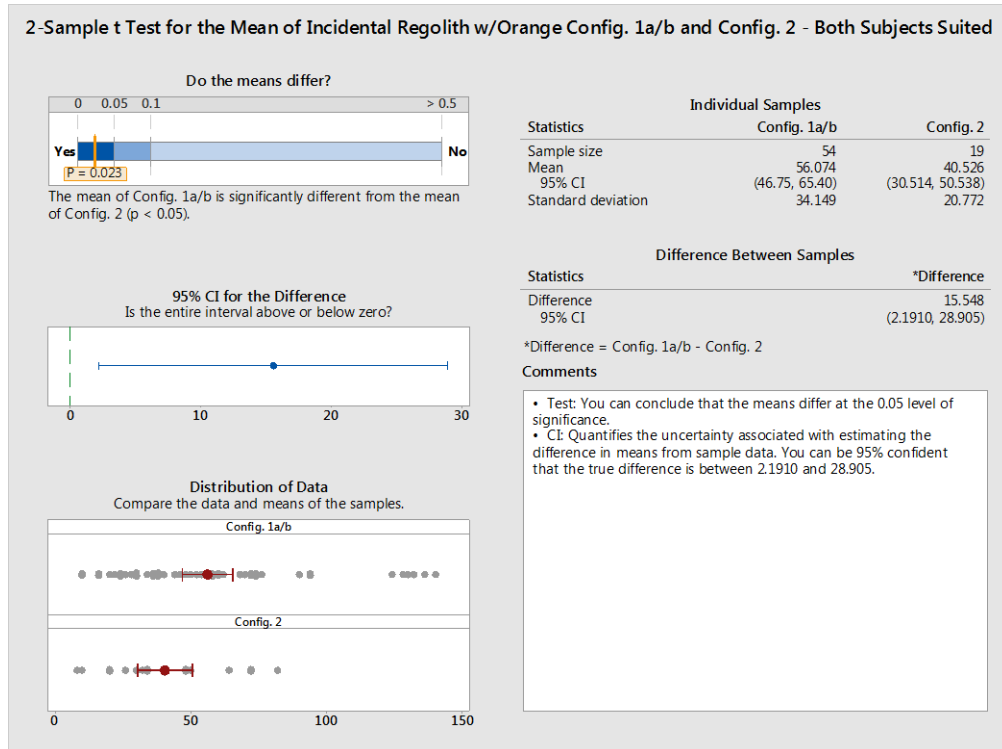

Figure 46. 2-Sample t test of incidental regolith collected with orange targets, baseline to Configuration 2, both subjects suited.

Since this difference was only significant for one of the target sizes in the above comparison it does raise the question whether specific target size matters when researching handle modifications to a tool. Data analysis was done for this and is partially represented in the bottom chart of Table 6. Since it is not pertinent to the question of handle modifications improving EVA geology tool performance it is not covered here. However, this may be relevant to future testing so it is briefly discussed in Appendix D.

Scoop Regolith Test

Data gathered during this test included the number of scoops during the allotted thirty seconds and the amount of regolith collected. Average regolith per scoop was then calculated to help mitigate any differences in a single run caused by such variations as terrain or local regolith simulant density. This was also done to help lessen differences

between the innate working styles between Subject 1 and Subject 2, such as smaller, faster scoops compared with larger, slower scoops.

It should be noted that the first replicate for Subject 1 unsuited allowed more time for the task than the rest, one minute instead of one half minute. Due to the increased time, this data point was not used for the analysis for the number of scoops per replicate or total regolith collected. It was left in with the amount of regolith per scoop data since this was a calculated average and consistent with Subject 1's data.

Figure 47 shows the amount of total regolith collected by each subject per replicate for a configuration. Subject 1 unsuited, top-left of the figure, has a noticeable difference between the two baseline configurations, 1a and 1b. This would suggest learning occurred during his unsuited runs. Comparing this to Subject 2's unsuited run, there is little change from Configuration 1a to 1b for Subject 2.

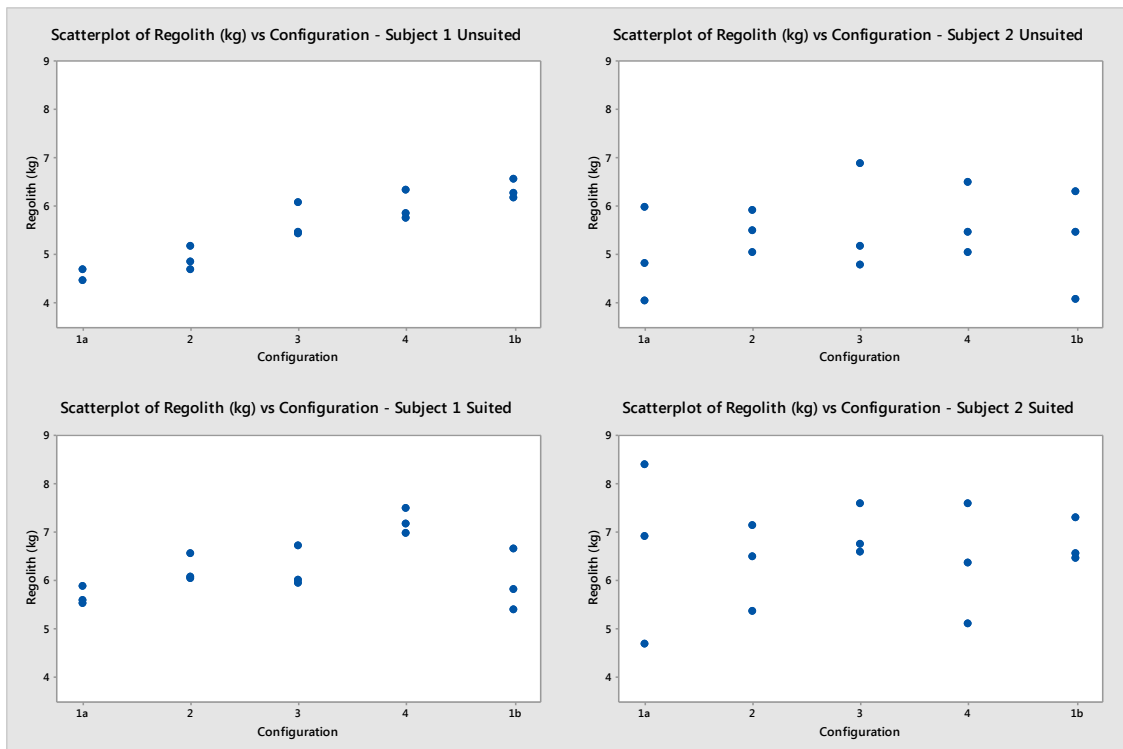

Figure 47. Chart of regolith collected vs. configuration sorted by subject and unsuited/suited.

Examining the suited portion of the data for Subject 1, bottom-left of the figure, the learning shown from Configuration 1a to 1b appears less pronounced than when unsuited and the data points are also still well grouped. Here there would appear to be some improvement with the modifications, in particular Configuration 4, both handles modified. Subject 2 suited, bottom-right, shows a larger spread between most replicates of the configurations and a fairly consistent average performance independent of the scoop's configuration. During the suited testing the subjects stated that the original handles felt a little too small when used with the gloves. Subject 1 wrote in the questionnaire that, while suited, "The thin handle made pushing it [the scoop] into the regolith difficult at times," and thought the increased diameter of the t-handle was more important than that of the shaft, but noted that having both was the preferred configuration.

In order to better understand the performance of the scoop and the subjects, the average regolith per scoop was calculated for each replicate. This calculated quantity can be seen in Figure 48 for both subjects, unsuited and suited. Subject 1 unsuited, top-left of figure, shows an increase across the configurations, suggesting learning may have occurred. Subject 2, unsuited appears to show no learning from the first base configuration test to the second. Suited data for Subject 1, bottom-left, suggests improvement with the modifications in comparison to combined baseline configurations. When comparing the modifications, Configuration 3 shows the lowest performance and Configuration 4 the highest. The suited data for Subject 2, bottom-right, seem relatively consistent, with a possible decrease in performance for Configuration 4.

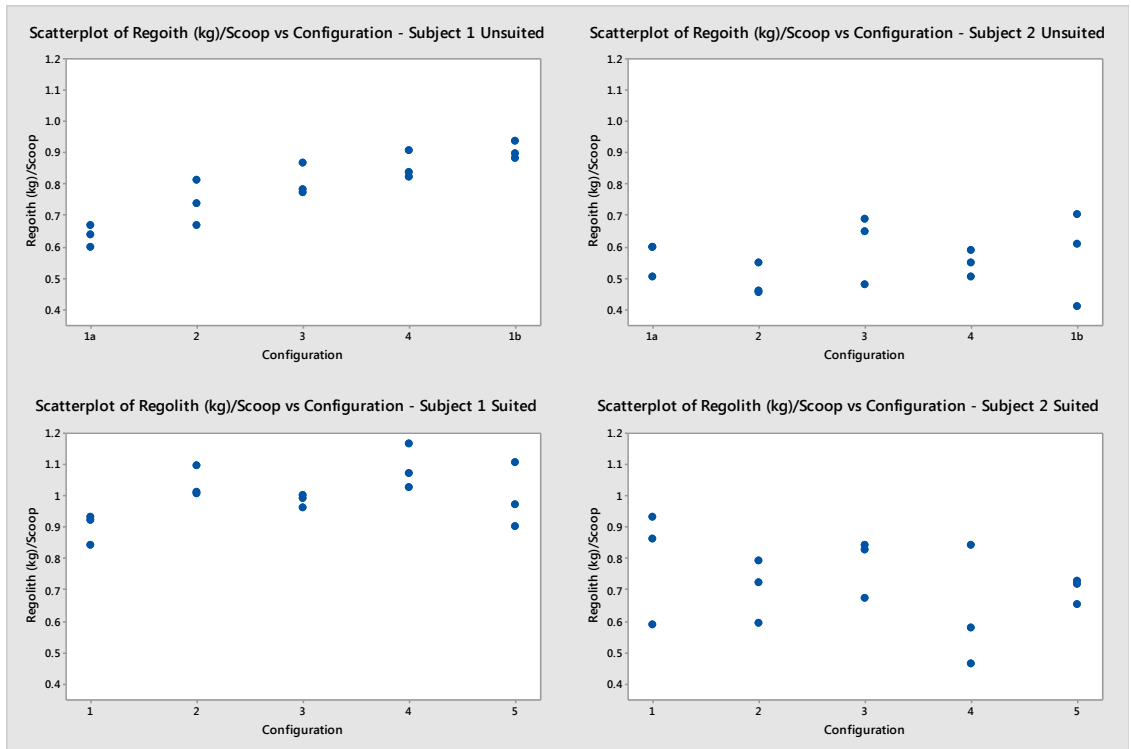

Figure 48. Chart of regolith/scoop vs. configuration sorted by subject and unsited/suited.

When performing the analysis on the suited data for number of scoops taken, amount of regolith collected, and average regolith per scoop, pairwise comparisons were made between the modified configurations and the combined baseline data, Configurations 1a and 1b. One relationship was found to be significant, $p < 0.05$, for Subject 1, but this did not carry over into the combined subject data, Table 7, and so is not discussed here.

Table 7. Scoop regolith test data.

	Total Scoops Taken:	Total Regolith (kg) Collected:	Average Regolith (kg) /Scoop:
Combined Baseline to:	Combined Subject Data		
Config. 2	Not Significant	Not Significant	Not Significant
Config. 3			
Config. 4			

Rake Test

The rake test collected data on the total number of targets collected, total passes for each subject, i.e., from the time the rake was placed on the regolith to the point it was lifted above the simulant's surface, and the number of targets dropped, i.e., targets that were picked up by the rake but did not make it into the container. The targets were not purposefully arranged in any particular pattern and were believed to be randomly distributed in the test area. For both subjects the rake was the most difficult of the three tools to work with. It was considered awkward due to its weight, size, and balance traits, which were most noticeable when shaking the excess regolith out of the basket.

One final general note about the rake test, the 4.0 inch diameter (red) targets had a tendency to become trapped in the basket area of the rake. This did occasionally slow the subjects down, though Subject 1 became very proficient at removing the red targets without disrupting his collection. These difficulties were logged during data collection. While this could result in test disruptions, it is conceivable that a sample may become lodged in the rake during mission operations and helps to illustrate possible beneficial changes to the design of the rake.

The performance of the rake in Figure 49 is illustrated by the total number of targets both subjects collected during each replicate for all configurations. The top-left graph of Figure 49 is Subject 1's unsuited runs and does not suggest the presence of learning, but possibly of fatigue. The top-right graph displays Subject 2's unsuited runs which do not demonstrate distinctive learning or fatigue.

Suited data are displayed at the bottom of Figure 49. Subject 1's performance, as seen in the bottom-left quadrant, would appear to have been negatively affected by

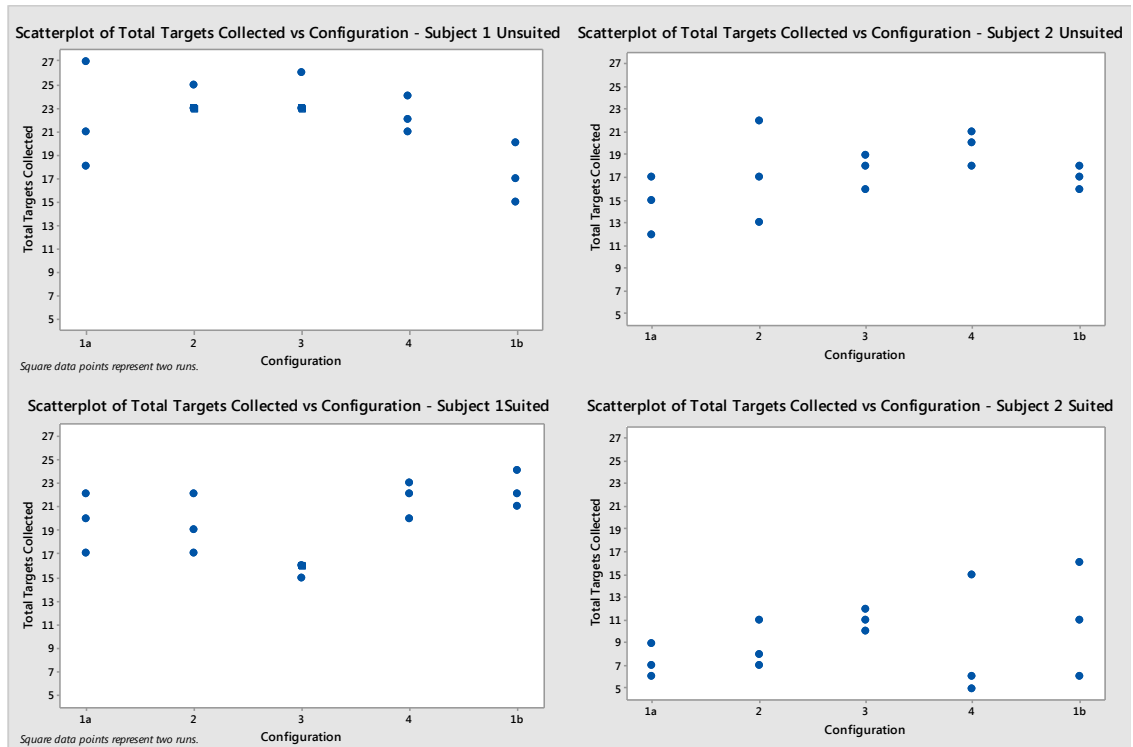

Figure 49. Chart of total targets collected vs. configuration sorted by subject and unsuited/suited.

Configuration 3, shaft modified. However, Subject 2's performance on the bottom-right of the figure may be showing some minor increase in performance for Configuration 3. The other configurations for both subjects appear more in line with the base configuration. For this suited testing both subjects discussed ways in which the handle modifications helped. Subject 1 said, "Control and ease of turning it [the rake] upside down [to deposit targets into the bin] was greatly improved." Subject 2 shared that "...due to the increased diameter, the fingers were able to grab it [the rake] better, reducing the fatigue in the palm."

The targets dropped, Figure 50, during the testing were used to measure error in accuracy for the rake. Most targets were dropped when attempting to place them in the collection container. Subject 1 and Subject 2's unsuited data, top of Figure 50, look to remain fairly constant across the baseline, Configurations 1a and 1b, and modified

configurations. Both suited subjects, lower half of Figure 50, show a possible decrease in error for Configuration 2, t-handle modified. Subject 1 shows a possible decrease in error from the baseline to Configuration 4, both handles modified.

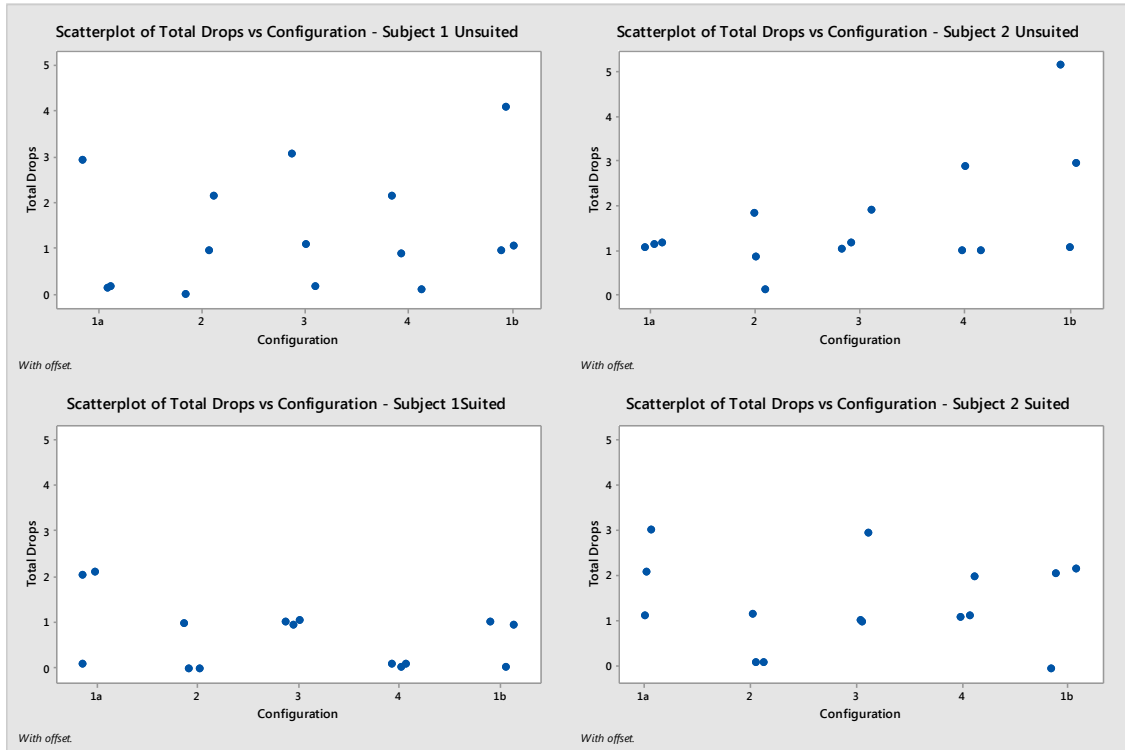

Figure 50. Chart of total targets dropped vs. configuration sorted by subject and unsited/suited.

When the data of total targets collected by both subjects were analyzed using pairwise comparison looking at the relationships between the baseline and each configuration only one relationship was found to be significant ($p < 0.05$) in Subject 1's data. The modified configurations were then compared pairwise with the baseline data set composed of both Configurations 1a and 1b for targets dropped. When these comparisons were completed one significant difference was found in each of the three data sets: Subject 1, Subject 2, and both subjects combined, Table 8. Only the difference found to be significant in the combined data is discussed here.

Table 8. Rake test data.

	Total Targets Collected:	Targets Dropped
Combined Baseline to:	Combined Subject Data	
Config. 2	Not Significant	Significant at $p < 0.05$
Config. 3		Not Significant
Config. 4		

When the subjects' suited data were combined, Figure 51, and compared against the baseline, the comparison to Configuration 2, t-handle modified, was found to be significant. The addition of the t-handle modification was found to significantly decrease the number of targets dropped, thus decreasing error.

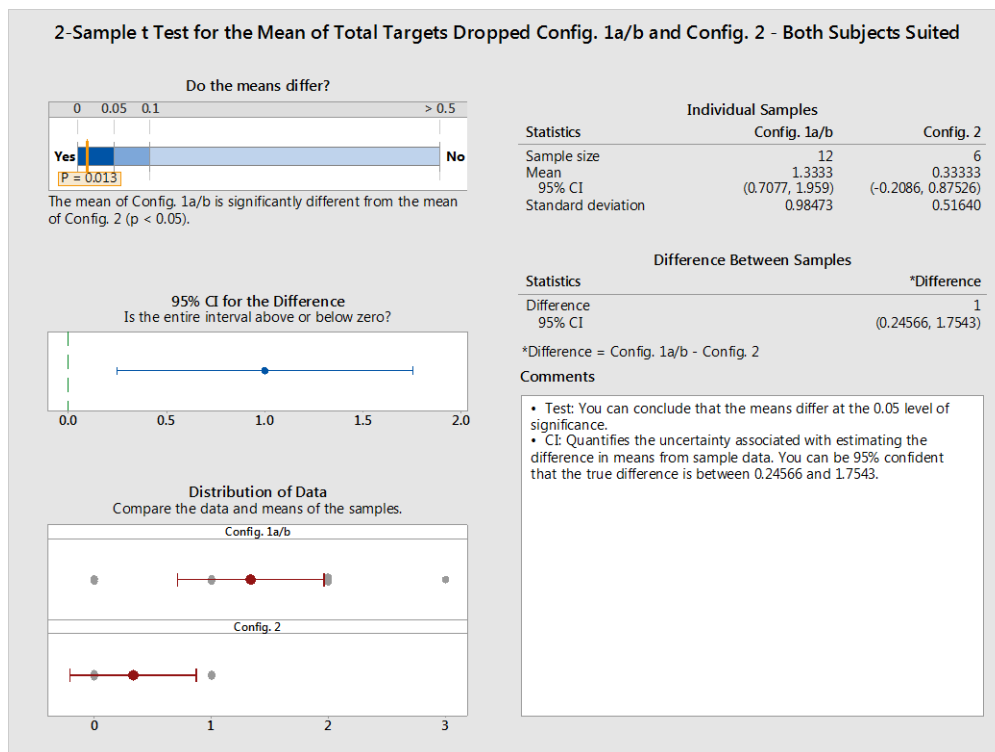

Figure 51. 2-Sample t test of targets dropped, Configuration 3 to Configuration 2, both subjects suited.

Tongs Test

During the testing of the tongs, the total targets collected, number of collection of attempts, number of drops, and how often containers were missed were recorded.

Collection attempts were counted as the number of times a subject attempted to initially

retrieve a target from the regolith surface. Number of drops was recorded as the number of times a target was released by the tongs after a successful initial retrieval and before attempting placement in the sample container. A missed container was a record of the subject intentionally releasing the target to place it in the container, but landing outside the container. This was counted separately from the previously mentioned target drops.

The design of the tongs allowed them to be used with a wide range of target diameters, which this test tried to capture. It is possible fewer or different sizes could have affected the outcome of the test. The smallest target (1.0 inch, purple) may have been able to be decreased in size and still have been retrievable. The largest target used (6.0 inches, green) was governed by the tongs maximum tine opening of 6.5 inches. Different sizes, larger or smaller, may also affect the subjects' fatigue, as well as the tong's performance.

Figure 52 shows the total number of targets collected by each subject unsuited

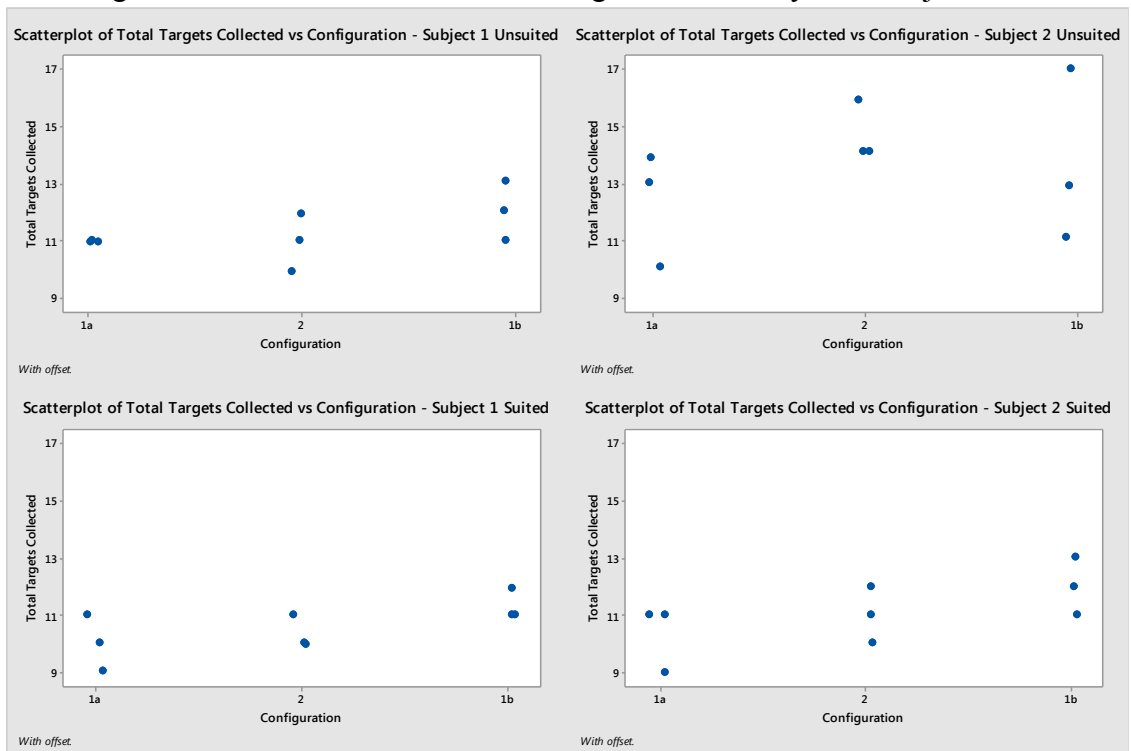

Figure 52. Chart of total targets collected vs. configuration sorted by subject and unsuited/suited.

and suited separated by configuration. Learning does not appear to be present for either unsuited subject. The suited testing by both subjects of the tongs is displayed in the bottom two graphs of Figure 52. Neither subject shows much change from one configuration to the next.

Figures 53, 54, and 55 report on the data used to evaluate error in the tongs. For these figures it should be noted that the baseline, Configurations 1a/b combined, have approximately twice as many data points as the modified tongs. Subject 1 and Subject 2 would then appear to increase their errors slightly in collection attempts from the baseline modified tool while decreasing error in both dropped targets and missed containers.

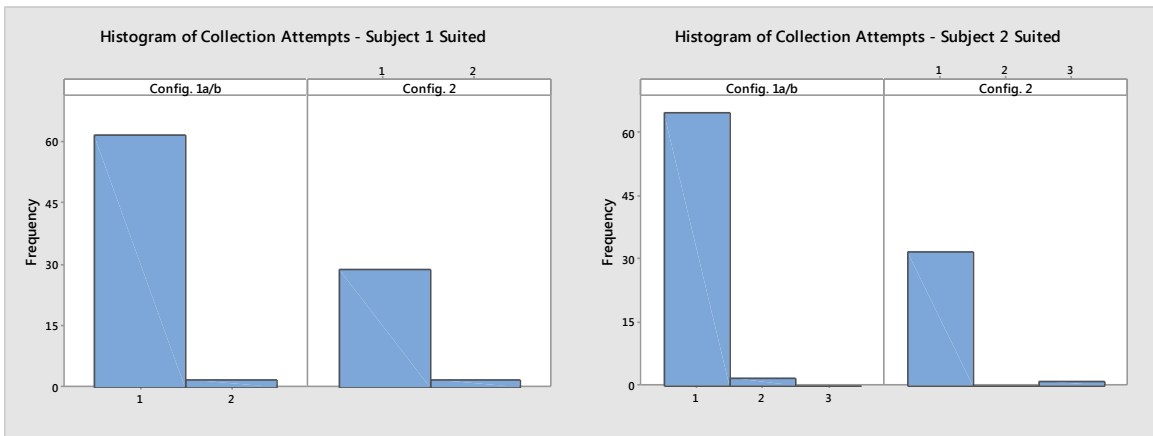

Figure 53. Chart of collection attempts by subject and configuration.

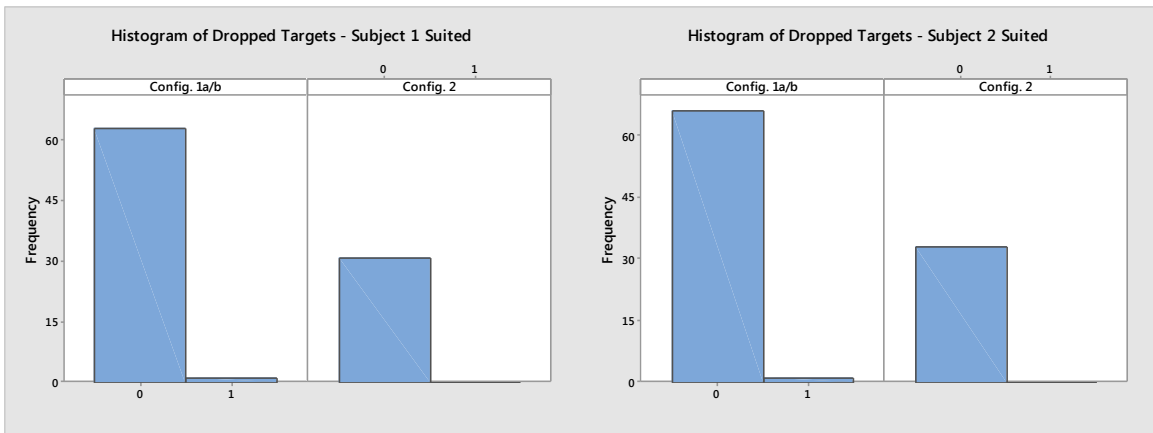

Figure 54. Chart of dropped targets by subject and configuration.

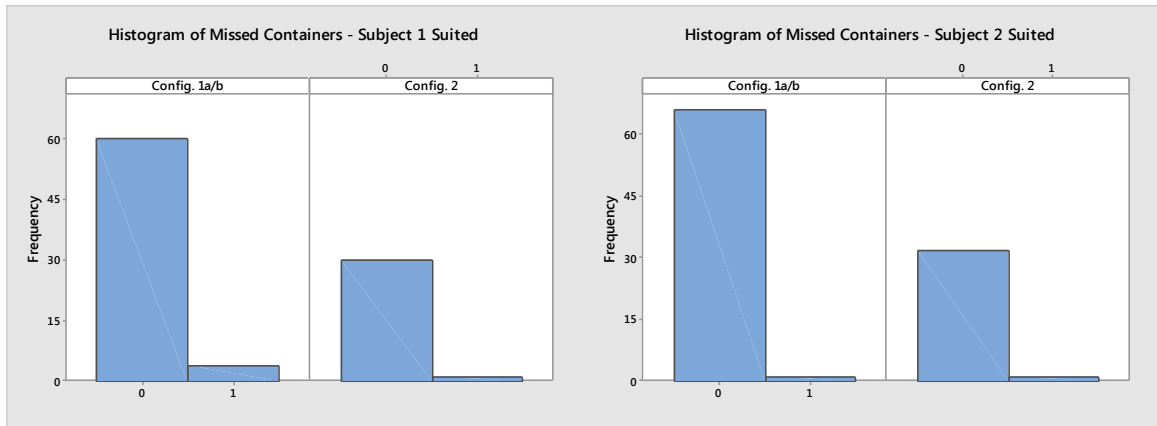

Figure 55. Chart of missed containers by subject and configuration.

When pairwise comparisons were performed with the combined baseline data, Configuration 1a and 1b, and the modified configuration, no significant differences, $p < 0.05$, were found. This included all data for total targets collected, number of collection attempts per target, times a target was dropped, and the times sample containers were missed. The data for Subjects 1 and 2 for all variables were also combined to increase the number of data points, but there were no significant differences, Table 9.

Table 9. Tongs test data.

	Total Targets Collected:	Collection Attempts	Targets Dropped	Missed Container
Combined Baseline to:	Combined Subject Data			
Config. 2	Not Significant	Not Significant	Not Significant	Not Significant

While statistically there were no significant changes, the subjects did express that they detected at least some increase in usability from the unmodified to the modified tongs in their questionnaires. Subject 1 wrote of the modification of the tongs, "While suited, I felt more accurate with the top handle on. I [had] less control when the top handle was removed." Subject 2 noted hand fatigue with the original tongs both unsuited and suited in the palm and fingers with the repetition of the task, however this fatigue was "nothing out of the ordinary" for such a task and unsuited the modification was

hardly noticeable. However, during the suited testing Subject 2 appears to have noticed a greater change in performance from the original to the modified tool, "...the larger diameter handles made it easier to manipulate and to actuate the closing portion. It was more comfortable after repetitive tasks."

CHAPTER VII

DISCUSSION AND CONCLUSIONS

This study examined the use of three Apollo era geology tools and the changes in their performance brought about by modifications to the original handle design while wearing a pressurized suit. The time allotted for the study allowed for the participation of two subjects. While performing this study in the regolith bin did limit the number of subjects, it increased the test environment validity and allowed for more realistic tool-environment interactions. While working with the simulant during the regolith collection test, Subject 1 commented on the sensation of a vacuum-like effect experienced with the scoop, displaying the subject's awareness of his surroundings and its attributes.

When the data were analyzed for each tool tested, there were no handle modifications that were found to make a significant difference in a tool's performance from that of the baseline configuration in both Subject 1 and Subject 2's individual data. Significant differences found in an individual subject's data did not always carry through to the combined data and so were not discussed. When significant differences were found between a modification and the baseline configuration in the combined subjects' data they were supported in some instances by a single subject's data, but not always.

The limited number of subjects, the difference in their pressurized, suited experience, and their apparent different methods when approaching the assigned tasks likely affected the results. These effects and the lack of significant differences found

across the two subjects during the testing of a tool's configurations impacts the conclusions that can be drawn from these data.

The scoop was tested performing two separate tasks: target collection and regolith collection. The data for the target collection showed no significant differences ($p < 0.05$), between the baseline scoop and any of the modified scoop configurations when total targets collected, collection attempts, targets dropped, missed containers, or incidental regolith were compared. A significant difference was only found when incidental regolith data was organized by target size. With this classification, the combined subject data showed that Configuration 2, t-handle modified, improved the scoop's accuracy for the largest target available, 2.0 inch diameter, over the base configuration. This significant difference discussed was also found in Subject 2's individual data set.

If this difference were found to be indicative of trends for the larger population the importance of modifying the scoop's handles could depend on the intended use of the scoop or the scientific needs for sample collections. The t-handle modification, Configuration 2, may prove useful to increase accuracy for larger targets while not significantly affecting the collection of smaller targets. However, if smaller targets are intended to be collected with the scoop and larger targets recovered by another method, i.e., tongs or gloved hands, increasing accuracy for smaller targets while perhaps sacrificing accuracy for larger targets may be reasonable, but this modification would not meet this need.

When the scoop was tested for regolith collection it was again found to have very few significant differences ($p < 0.05$) between the original configuration and the modified configurations. In this area of testing, only Subject 1 showed any significant difference in

performance and this did not carry through to the combined data. Since most differences for either scoop test were not significant between the base configuration and the modified configurations for the subjects, either separately or together, it is likely that these handle modifications did not change performance in a meaningful way.

The rake was tested collecting targets and showed only one significant difference ($p < 0.05$) in the number of targets collected and three significant differences in the number of targets dropped between base configuration and the modified configurations. Only one of these significant differences was found in the combined subjects' data. The errors for the rake, as measured by the number of targets dropped, were significantly decreased in the combined data with the t-handle modification, Configuration 2. This performance improvement was also seen in Subject 2's individual data, but was not found for Subject 1.

Configuration 2's significant decrease in error and no significant difference in target collection compared to the baseline, would indicate that errors declined while target collection remained unaffected. If these two circumstances were duplicated in a study using a larger sample size, there would be evidence that modifying both handles may help decrease error while not decreasing overall performance. Yet, as with the scoop handles in general, modifications would not seem to make consistent, measurable changes to the performance of the rake.

The tongs, unlike the scoop and rake, only had one handle modification tested. There were no significant differences, $p < 0.05$, found in any of the data collected during this test: total targets collected, number of collection attempts, number of targets dropped, and number of missed containers.

Overall, there are little objective data that support a change in performance for any of the modifications to the three tested tools. This could be because the modifications tested were not effective enough to make a measurable difference in performance, the data collected did not sufficiently measure the parameters of interest, or changing the handle diameter does not affect the suited use of the tools. There are some data that point to either detrimental or beneficial changes due to different configurations, but in order to answer these questions with greater clarity and reliability a larger sample size will be required.

The objective data may show little support for the study of such changes, but the subjective data submitted by both subjects favored the modifications over the original tools' configurations. This was especially true of the scoop and the rake. Less improvement was noted for the tongs, but the consensus of the two subjects still favored the modified over the original. This difference in perceived versus actual performance cannot be readily explained within the scope of this experiment, but may suggest additional study could be warranted.

CHAPTER VIII

FUTURE RESEARCH DIRECTIONS

This research highlighted several important factors for testing future EVA tools. These observations pertain to various portions of the study: experiment design, procedure, tool modifications, and location.

Testing

It was anticipated that two subjects would not provide enough data points to fully understand the implications of the tool modifications for generalization with respect to usability, so increased subject numbers would be beneficial in the future. What was unexpected was how different the two subjects performances were when compared with each other. For subject selection, the most concern was placed on finding subjects that would be able to comfortably operate in the suit, preferably with some experience working within pressurized suits. No personality comparison or personality trait inventory was performed. While anthropomorphic differences between subjects may explain some performance variation, they cannot account for all.

Having a wide pool of astronaut-like candidates in both physical and mental characteristics certainly has its advantages, but for the sake of experimental purposes, it may be worth sorting through the personalities of test subjects and choosing those with similar relevant character traits to be used as a control during the experiment. This screening may benefit from being taken further and selecting subjects for specific personality traits or using select-out methods to avoid other traits. The importance of such

traits in part depends on how large of a study is being conducted, with those performed with larger subject pools being less affected. The relevant positive or negative traits may vary depending on the experimental set-up or hypothesis. For example, the way subjects are timed could make their degree of competitiveness relevant or whether they value quality or quantity in task performance. Another potentially important personality trait in such a test is how the subject will deal with irritations that arise during the testing. For example, during this experiment the 4.0 inch (red targets) had a tendency to stick in the rake due to their size and the subjects had different reactions to this occurrence.

This test was conducted with three runs of each tool configuration. It is recommended that this be increased in any similar future testing. Disregarding former adaptations for a tool, as well as the adjustments to a new handle configuration, may affect the data collected for a tool near the beginning of its runs. Several tool configurations had data with a wide distribution between points making any outliers difficult to determine because of the low number of data points, three runs. However, the possibility of fatigue is very real, as is the need to try and control fatigue over the length of a testing period. Therefore adding too many runs may be as detrimental as having too few.

Targets during this test were all spherical in shape so the tool-target interface would be as similar as possible for each interaction. Using different shapes, including natural target shapes and sizes could provide additional insight into the tools' functioning that was not visible in the more controlled testing of this experiment.

The data collection process was satisfactory, though a new system for the scoop target collection test needs to be developed. The small bags in the cups required too much

attention and the process of placing the bags inside the cups and removing them was time consuming. These delays caused more down time during the testing than was ideal for scheduling, though it permitted the subjects to have a rest period before a new configuration of the scoop which allowed for less compounded fatigue between configurations. Ideally, the regolith and target would be scooped into a cup or box with its own dedicated balance to measure the mass of the regolith, which would allow the regolith data to be recorded and dumped immediately after the trial. Several of the cups or boxes could be placed near the test site.

Beyond the data collected in this test, motion capture could be a useful tool as well as more thorough collection of subjective data. Motion capture would allow for a comparison of the motions of subjects to pinpoint more specifically and accurately their differences in functioning with the tools. It could also be used to track the tools themselves, allowing for collection of data on deformation in tool structure, causes of mishaps such as dropped targets during testing, and changes in tool-target interactions based on target size or shape. Also subjective data was not a focus of this study, but showed that there was a perceived difference in tool performance, if not necessarily a measurable one. Collecting subjective data using an established metric for comparison of the modified to baseline tools may help pinpoint where the differences in data types are to be found and how real they are.

Manipulating the environment to help tease out performance differences in handle diameters could prove beneficial. If a vacuum environment, i.e., a glove box, could be used for additional testing, measures such as grip strength and endurance could be recorded for different handle diameters while working against a fully pressurized glove.

Tool Modifications

In this study the tool handles were only tested at two different diameters: the original diameter and the single modified diameter. Only testing two sizes opens the study up for uncertainty since it is unknown if a special case exists. Either could be at a maximum or minimum for performance quality or could be on the line between improvement and decline or decline and improvement. This brings about the idea of testing a range of handle sizes, starting at the initial handle diameter and increasing through diameters that are large enough to show detriment in performance. This process could allow a more systematic charting of the effects of various handle diameters and possibly distinguish trends that could determine where the maximum usability of the tool with respect to handle diameter is located.

The handle modifications were not permanent during this study. They worked well and caused little difficulty, the only exception being some sliding of the shaft cover on the rake when turned to place the targets in the bin. This was mainly seen during Subject 2's testing, but was not commented on by either subject. However, creating tools, or at least fully modified handles, could be important for future studies. Manufacturing the handles as they would be for flight will allow for the mass variation and change in balance to be taken into account when discussing the tools' usability.

While this study focused on the changes to the handle diameters, other observations of the functioning of the tools were also made during the course of testing. Observations of the subjects performing the tests suggested that the length of the tools may be another aspect to focus on. In particular while using the scoop the subjects remained in a knees and back bent posture for the majority of the testing. The tongs also

required regular bending over during use. Subject 1 noted that using the rake to reach the target bin required more bending at the knees for the suited portion of the test, compared with the unsuited portion. The different angles the tool heads are designed to be used at could also be an avenue worth exploring either by itself or in conjunction with other modifications.

Subjects also noted other issues that arose with tool function. Both subjects commented on the interference of the palm bars with the use of the tools, although as they became accustomed to this interaction it became less noticeable. This interaction between the tools and palm bars will be dependent on the suit being used for the operations. Subject 2 noted that the enclosed portion of the scoop was a problem while retrieving targets of a larger diameter.

The most discussed tool was the rake. Between the three tested tools it was the most awkward and tiring to use and Subject 2 stated, "It clearly is the tool that needs [the most] redesign of all the tested ones." From the subject reports and the observations of the test there are some design changes that can be recommended for the rake other than what has been previously stated. Reducing the weight to lessen fatigue and redistribute the center of gravity could be an important adjustment depending on what planetary body the tool is being redesigned for use on. If these changes entail reducing the tool head, considering what this would do to the comparison of productivity to performance would be an important relationship to examine. Further, redesigning the rake basket so that any sample that can enter the front of the basket will be less likely to become lodged at the rear could help eliminate some of the irritation and extra fatigue experienced during sampling. It may also be important to determine whether the benefits of adding a way to

release targets from the back of the rake basket, instead of having to turn it, would be worth complicating the design, and therefore introducing a greater possibility of mechanical failures. Finally the tines that stick out from the basket may need to be redesigned. The rake is typically pulled toward its user and the tines are pieces of metal protruding from the rake, possibly producing a concern for a suit puncture or other equipment damage. At a minimum this design feature may need to be reconsidered to ensure compliance with NASA standards. They also have a tendency to bend, which could cause sample collection and release problems.

Regolith Bin Testing

This research was the first suited test to be performed in the regolith bin at KSC and, as such, unanticipated issues appeared during testing. Adjustments were made but some possible solutions could not be tested. Arguably the most important part of the suited test was providing the air to pressurize the suit. This was provided by an air compressor and filter placed adjacent to the regolith bin on the side of the bin with the air lock. There are not any fixtures to allow for the passing of the air or the air umbilical into the bin. However, there was a section of the bin wall that had been replaced with material held in place by Velcro. By opening a small portion of the Velcro the air umbilical could be passed through to the regolith bin, see Figure 56. The air umbilical was then suspended from a rope and pulley system above the regolith bin, see Figure 57. This permitted the subjects free movement since they were not required to drag the umbilical along with them. It also reduced the dust kicked up in the regolith bin, helped preserve the designated test areas, and helped keep both subjects and study staff from becoming entangled in the umbilical. If a regolith bin were to be dedicated to human testing, or



Figure 56. Air umbilical being fed into the regolith bin.

geared more toward human testing, it could be beneficial to have fittings placed at strategic points along the perimeter to allow for easy access to a sufficient, stable supply of air and perhaps a secondary, reserve supply. Another option would be to connect the umbilical outside the regolith bin and then suspend it so it would come over the top of the bin and did not interact with the regolith at all.



Figure 57. Air umbilical being suspended from pulley system and tied off.

The other issue that arose from the umbilical arrangement was the necessity to first connect the subject to the umbilical outside the bin before they could go through the airlock and into the bin. This meant feeding the subject end of the umbilical out through the airlock doors, which resulted in an inability to completely close the doors during this procedure, and having to attach the umbilical in the suit donning area. This required extra hose length and meant the umbilical had to be carefully monitored while the subject entered the bin to ensure neither the subject nor the study staff became entangled with it. Once the subject was inside the regolith bin proper the umbilical was then attached to the pulley system and raised. There was also the concern that the quick disconnect on the umbilical would become contaminated with regolith after it was disconnected from the suit and taken back into the regolith bin or airlock so the airlock doors could be closed. To prevent any issues from this, the hose end was always wiped down and covered in plastic that was taped in place after it was disconnected from the suit.

Providing solutions for continuous airflow to a suited subject from outside to inside the regolith bin while maintaining a good setup for both safety and convenience is complex. This is made more complicated if it is a procedural requirement to pump air external to the regolith bin to the suited subject, as it was for this study. One possibility would be a portable system that could be carried by the suited subject into the airlock where they would be connected to the integrated system. If a portable system is not ideal a separate connection outside in the donning area could be used into the airlock and then replaced, but this may only be practical for suits with two connections for the air umbilical; such as the NDX-1 that has a connection on the hard upper torso and one in the helmet. If the umbilical itself were to be connected outside the regolith bin and was to

be suspended over the top, as mentioned previously, the regolith bin could be designed to allow for the passage of the umbilical through designated points in the structure.

During the test a wired communication system was used to ensure constant, reliable contact between the suited subject, study coordinator, and the safety officer. These three people were constantly connected. The study coordinator, within the bin, carried the communications box and the other two people were attached to the coordinator through that box. The communications cable to the safety officer manning the compressor was fed through to the outside of the bin in the same manner as the air umbilical. This meant the coordinator could only move as far away from either person as the cable length would allow. This was not an issue between the coordinator and the subject, but was an issue once the safety officer was connected. Once that connection was made, the coordinator could not quite reach the far corner of the regolith bin, although this was not a problem for the subject who had free movement about the entire surface of the regolith bin. These cables were also not suspended and had a propensity to tangle with themselves, the other communications cables, or the air umbilical.

A wired communications set up in the bin with strategic connections placed around the inside perimeter or suspended above the bin, as mentioned for the air umbilical, could be ways to help alleviate this problem. Another option would be a built in wireless system that would allow multiple people to monitor and participate in communications with the additional possibility of recording the conversation. In this study, a wireless transmitter was connected to the communications box to allow for the conversation to be monitored by people not directly wired into the system, in part for safety concerns, and for the communications to be recorded. A built in communications

system that would work well with different types of suits being tested, as well as with the respiratory protection required while in the regolith bin, would help simplify operations.

A camera system could also be hardwired into the building. For this test, Gopro cameras were used to record video, but battery and storage limitations meant that the entire test could not be recorded without extending the test time to allow for data dumps and battery recharging or changing. With a built-in system, cameras could run off the power supply of the building and be connected to a hard drive for video data storage. Ideally these cameras would allow for monitoring and adjustment in real time to permit the best video quality. This would also help reduce set-up and tear-down time for the test as well as the time spent in between tests performing data dumps and other camera maintenance.

An idea that worked well was using the small air compressor hose available in the regolith bin to remove regolith from the suit after the test and before the subjects left the airlock. One suggestion would be to make a similar hose available in the airlock so it is more accessible to the study staff at the end of the test. The hose would be less likely to become tangled or trip up staff within the regolith bin. For this test, a box was placed in the regolith bin so that the suited subjects could sit during their rest periods or whenever they deemed it necessary. It was placed in different positions in the bin, but always so that the subject would be able to lean back against a steady surface. It is conceivable that a more stable place for a suited subject to sit within the regolith bin could be convenient during some testing, but does not appear to be a vital design consideration since, as was done for this test, something can always be taken in to be used as a chair.

APPENDICES

APPENDIX A Acronyms Used

Acronyms:

ALSRC - Apollo Lunar Sample Return Container

BP-1 - Black Point 1 Lunar Regolith Simulant

EMU - Extravehicular Mobility Unit

EVA - Extravehicular Activity

GDRD - Generic Design Requirements Document

HIDH - Human Integration Design Handbook

HIDP - Human Integration Design Process

ISS - International Space Station

JSC - Johnson Space Center

KSC - Kennedy Space Center

LCG - Liquid Cooling Garment

LRL - Lunar Receiving Laboratory

LRV - Lunar Roving Vehicle

MDRS - Mars Desert Research Station

MSIS - Man-Systems Integration Standard

NDX-1 - North Dakota Experimental 1

OSHA - Occupational Safety and Health Administration

PPE - Personal Protective Equipment

SFHSS - Space Flight Human-System Standard

UHT - Universal Handling Tool

UND - University of North Dakota

Appendix B
Anthropomorphic Measurement Figures as Related to Table 2

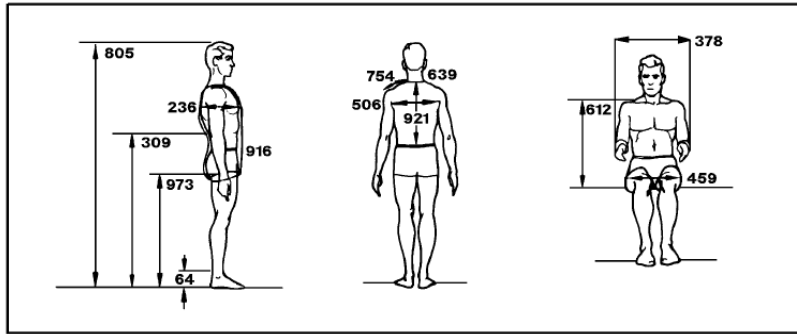

Microgravity notes	No.	Dimension	5th percentile	50th percentile	95th percentile
1	805	Stature	169.7 (66.8)	179.9 (70.8)	190.1 (74.8)
1	973	Wrist height			
	64	Ankle height	12.0 (4.7)	13.9 (5.5)	15.8 (6.2)
1	309	Elbow height			
	236	Bust depth	21.8 (8.6)	25.0 (9.8)	28.2 (11.1)
1	916	Vertical trunk circumference	158.7 (62.5)	170.7 (67.2)	182.6 (71.9)
2 1	612	Midshoulder height, sitting	60.8 (23.9)	65.4 (25.7)	70.0 (27.5)
	459	Hip breadth, sitting	34.6 (13.6)	38.4 (15.1)	42.3 (16.6)
1	921	Waist back	43.7 (17.2)	47.6 (18.8)	51.6 (20.3)
	506	Interscye	32.9 (13.0)	39.2 (15.4)	45.4 (17.9)
	639	Neck circumference	35.5 (14.0)	38.7 (15.2)	41.9 (16.5)
	754	Shoulder length	14.8 (5.8)	16.9 (6.7)	19.0 (7.5)
	378	Forearm-forearm breadth	48.8 (19.2)	55.1 (21.7)	61.5 (24.2)

Values in cm with inches in parentheses

Figure 58. "Body Size of the 40-year-Old American Male ... for Year 2000 in One Gravity Conditions" (Man-systems, 1995).

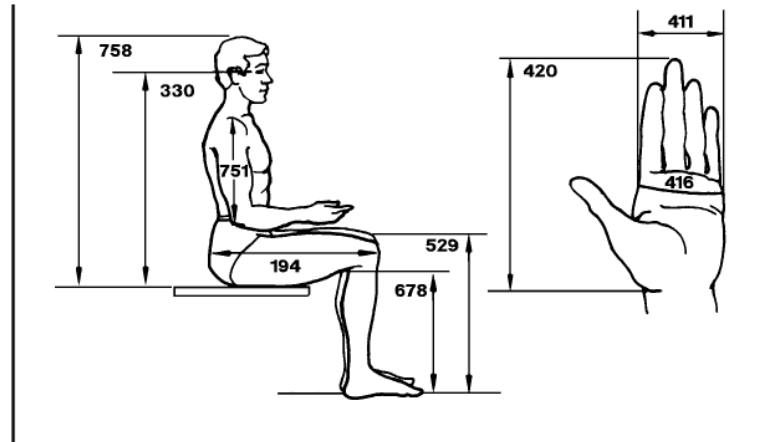

Microgravity notes	No.	Dimension	5th percentile	50th percentile	95th percentile
2 1	758	Sitting height	88.9 (35.0)	94.2 (37.1)	99.5 (39.2)
2 1	330	Eye height, sitting	76.8 (30.3)	81.9 (32.2)	86.9 (34.2)
4	529	Knee height, sitting	52.6 (20.7)	56.7 (22.3)	60.9 (24.0)
	678	Popliteal height	40.6 (16.0)	44.4 (17.5)	48.1 (19.0)
	751	Shoulder-elbow length	33.7 (13.3)	36.6 (14.4)	39.4 (15.5)
	194	Buttock-knee length	56.8 (22.4)	61.3 (24.1)	65.8 (25.9)
	420	Hand length	17.9 (7.0)	19.3 (7.6)	20.6 (8.1)
	411	Hand breadth	8.2 (3.2)	8.9 (3.5)	9.6 (3.8)
	416	Hand circumference	20.3 (8.0)	21.8 (8.6)	23.4 (9.2)

Figure 59. "Body Size of the 40-year-Old American Male ... for Year 2000 in One Gravity Conditions" (Man-systems, 1995).

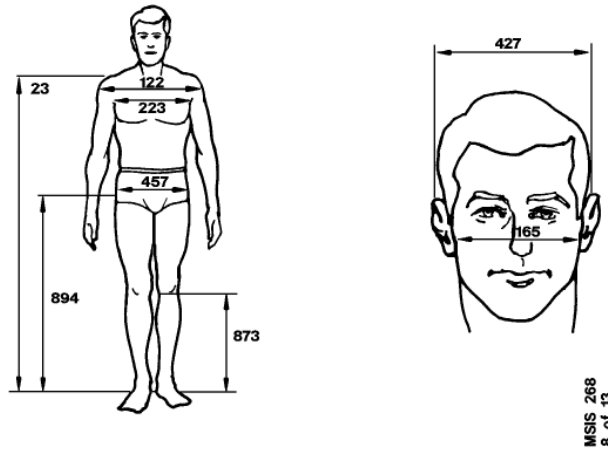

Microgravity notes	No.	Dimension	5th percentile	50th percentile	95th percentile
3 1	23	Acromial (shoulder) height	138.0 (54.3)	147.6 (58.1)	157.3 (61.9)
	894	Trochanteric height	88.3 (34.8)	95.8 (37.8)	102.9 (40.5)
	873	Tibiale height			
	122	Bideltoid (shoulder) breadth	44.6 (17.6)	48.9 (19.3)	53.2 (20.9)
	223	Chest breadth	29.7 (11.7)	33.2 (13.1)	36.7 (14.4)
	457	Hip breadth	32.7 (12.9)	35.8 (14.1)	39.0 (15.4)
	165	Bizgomatic (face) breadth	13.4 (5.3)	14.3 (5.6)	15.1 (6.0)
	427	Head breadth	14.8 (5.8)	15.7 (6.2)	16.5 (6.5)

Values in cm with inches in parentheses

Figure 60. "Body Size of the 40-year-Old American Male ... for Year 2000 in One Gravity Conditions" (Man-systems, 1995).

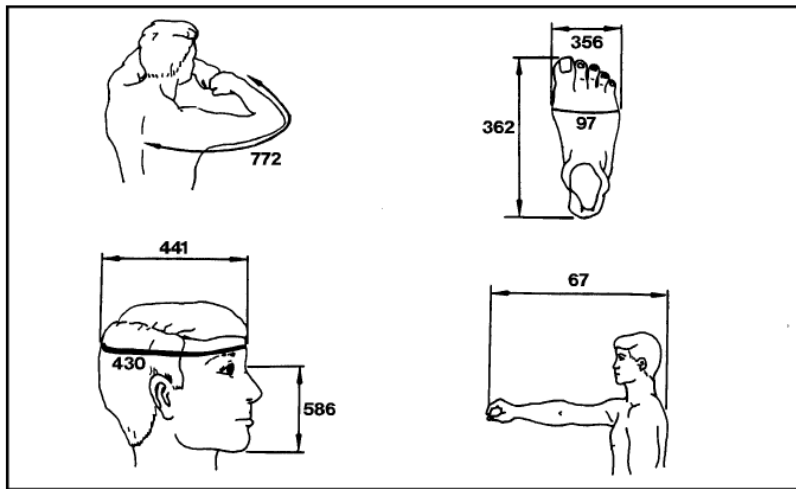

Microgravity notes	No.	Dimension	5th percentile	50th percentile	95th percentile
	67	Thumb-tip reach	74.9 (29.5)	81.6 (32.1)	88.2 (34.7)
	772	Sleeve length	86.2 (33.9)	92.0 (36.2)	97.9 (38.5)
	441	Head length	18.8 (7.4)	20.0 (7.9)	21.1 (8.3)
	430	Head circumference	55.5 (21.8)	57.8 (22.8)	60.2 (23.7)
	586	Menton-sellion (face) length	11.1 (4.4)	12.1 (4.8)	13.1 (5.2)
	362	Foot length	25.4 (10.0)	27.3 (10.8)	29.3 (11.5)
	356	Foot breadth	9.0 (3.6)	9.9 (3.9)	10.7 (4.2)
	97	Ball of foot circumference	23.1 (9.1)	25.1 (9.9)	27.2 (10.7)

Values in cm with inches in parentheses

Figure 61. "Body Size of the 40-year-Old American Male ... for Year 2000 in One Gravity Conditions" (Man-systems, 1995).

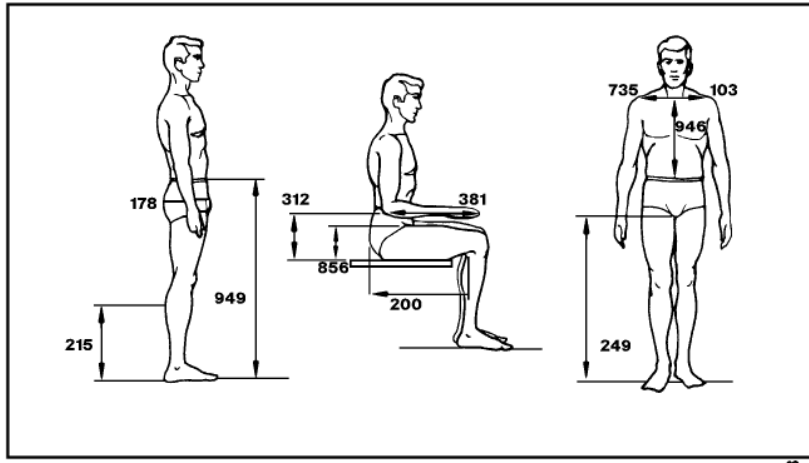

Microgravity notes	No.	Dimension	5th percentile	50th percentile	95th percentile
	949	Waist height	100.4 (39.5)	108.3 (42.6)	116.2 (45.7)
	249	Crotch height	79.4 (31.3)	86.4 (34.0)	93.3 (36.7)
	215	Calf height	32.5 (12.8)	36.2 (14.3)	40.0 (15.7)
	103	Biacromial breadth	37.9 (14.9)	41.1 (16.2)	44.3 (17.5)
1	946	Waist front	37.2 (14.6)	40.9 (16.1)	44.5 (17.5)
	735	Sleeve circumference	44.4 (17.5)	49.0 (19.3)	53.6 (21.1)
	178	Buttock circumference	91.0 (35.8)	100.2 (39.4)	109.4 (43.1)
1 2	312	Elbow rest height	21.1 (8.3)	25.4 (10.0)	29.7 (11.7)
	856	Thigh clearance	14.5 (5.7)	16.8 (6.6)	19.1 (7.5)
	381	Forearm hand length			
	200	Buttock popliteal length	46.9 (18.5)	51.2 (20.2)	55.5 (21.9)

Notes:

Figure 62. "Body Size of the 40-year-Old American Male ... for Year 2000 in One Gravity Conditions" (Man-systems, 1995).

- Configuration #1 None
- Configuration #2 Top Handle
- Configuration #3 Bottom Handle
- Configuration #4 Both

Subject #
 Scoop
 Regolith
 Sampling:

Configuration # 1	Scoops	Total Scoops	Mass of Collected Regolith
Sample 1			
Sample 2			
Sample 3			

Configuration # 2	Scoops	Total Scoops	Mass of Collected Regolith
Sample 1			
Sample 2			
Sample 3			

Configuration # 3	Scoops	Total Scoops	Mass of Collected Regolith
Sample 1			
Sample 2			
Sample 3			

Figure 64. Scoop regolith test data collection sheet, page 1.

Configuration # 4	Scoops	Total Scoops	Mass of Collected Regolith
Sample 1			
Sample 2			
Sample 3			

Configuration # 1	Scoops	Total Scoops	Mass of Collected Regolith
Sample 1			
Sample 2			
Sample 3			

Figure 65. Scoop regolith test data collection sheet, page 2.

Subject #
 Rake

Configuration #1 None
 Configuration #2 Top Handle
 Configuration #3 Bottom Handle
 Configuration #4 Both

Bulk Target
 Sampling:

Configuration #	Passes	Total Passes	Collection Attempts	Drops	Number of Samples Collected	Mass of Regolith
Sample 1						
Total Time 1:						
Sample 2						
Total Time 2:						
Sample 3						
Total Time 3:						

	Sample 1		Sample 2		Sample 3	
	Color	Size	Color	Size	Color	Size
1						
2						
3						
4						
5						
6						
7						
8						
9						
10						
11						
12						
13						
14						
15						
16						
17						
18						
19						
20						
21						
22						
23						
24						
25						
26						
27						
28						
29						
30						

Figure 66. Rake test data collection sheet.

Subject # [redacted]
 Tongs

Individual Target

Sampling: Configuration # [redacted]

Total Time: [redacted]

Samples Collected: [redacted]

Total Time: [redacted]

Run #	Color	Size	Collection Attempts	Drops	Container Chosen	Missed Container
Target 1						
Target 2						
Target 3						
Target 4						
Target 5						
Target 6						
Target 7						
Target 8						
Target 9						
Target 10						
Target 11						
Target 12						
Target 13						

Configuration #1 None
 Configuration #2 Handle

Figure 67. Tongs test data collection sheet. Target lines were continued onto a second page.

Appendix D

Example of effects of target diameter

The incidental regolith collected with the three target sizes (1.0, 1.5, and 2.0 inches: purple, yellow, and orange respectively) during the scoop target test was compared by configuration for both individual subject data and the combined subject data. There was one significant difference found for Subject 1 but there was no carry over to the combined data. Another configuration displayed a significant difference exclusively in the combined data. Only the difference in combined data is discussed here. The subjects' combined data showed a significant difference between the incidental regolith collected with the purple and orange targets for the baseline configuration, Figure 68. An accuracy preference is indicated for the smaller target size as displayed by

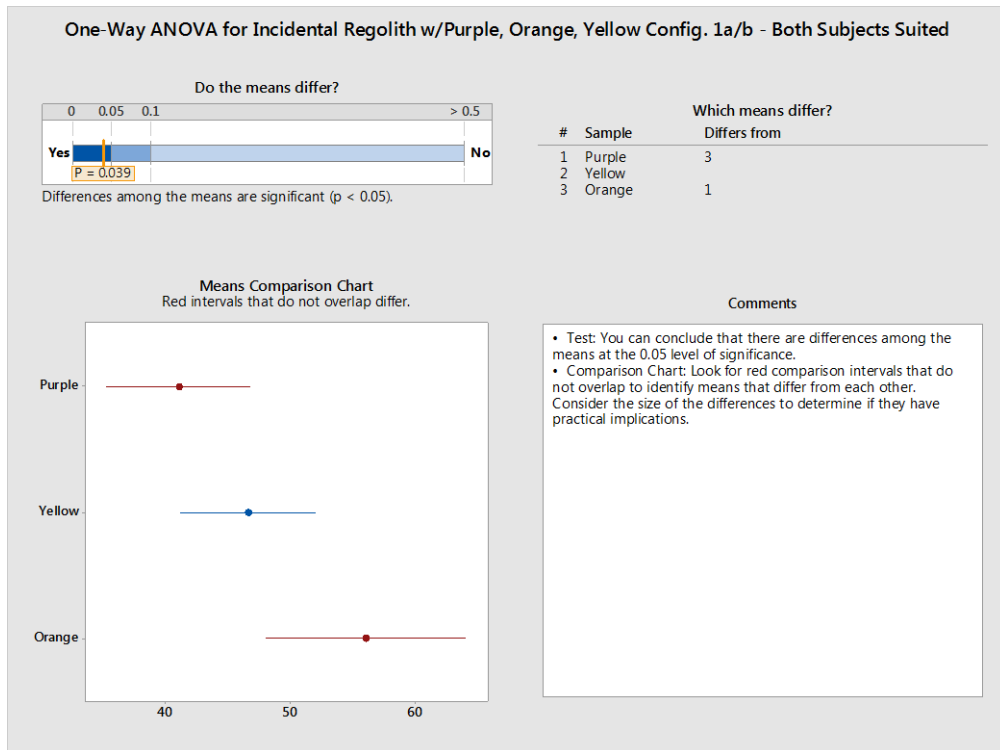

Figure 68. One-way ANOVA for incidental regolith compared by color, baseline configuration, both subjects suited.

the purple, smallest targets, being collected with the least amount of regolith. The mean amount of regolith collected increases with target diameter, showing a decrease in accuracy with an increase in target size, though this was not true of all individual comparisons. This significance was not shown in the combined data for any other configuration.

REFERENCES

- Allton, Judith Haley. National Aeronautics and Space Administration. (1989). Catalog of Apollo lunar surface geological sampling tools and containers. (JSC-23454).
<https://www.hq.nasa.gov/alsj/tools/Welcome.html>
- Allton, Judith H. National Aeronautics and Space Administration. (2009). Lunar samples: Apollo collection tools, curation handling, Surveyor III and Soviet Luna samples. Lunar Regolith Simulant Workshop, Huntsville, Alabama, United States of America. (JSC-17994).
<http://ntrs.nasa.gov/archive/nasa/casi.ntrs.nasa.gov/20090011852.pdf>
- Allton, J.H. & Dardano, C.B. (1988). How successful were the lunar sampling tools: Implications for sampling Mars. In Lunar and Planetary Inst., Workshop on Mars Sample Return Science, 30-31.
<http://articles.adsabs.harvard.edu/full/1988msrs.work...30A>
- Bailey, N.G. & Ulrich, G.E. U.S. Geological Survey. (1974). Apollo 11 voice transcript: Pertaining to the geology of the landing site. (USGS-GD-74-026).
<https://www.hq.nasa.gov/alsj/a11/Apollo11VoiceTranscript-Geology.pdf>
- Bailey, N.G. & Ulrich, G.E. U.S. Geological Survey. (1975). Apollo 12 voice transcript: Pertaining to the geology of the landing site. (USGS-GD-74-027).
<http://www.lpi.usra.edu/lunar/documents/Apollo12VoiceTranscript-Geology.pdf>
- Bailey, N.G. & Ulrich, G.E. U.S. Geological Survey. (1975). Apollo 14 voice transcript: Pertaining to the geology of the landing site. (USGS-GD-74-028).
<http://www.lpi.usra.edu/lunar/documents/Apollo14VoiceTranscript-Geology.pdf>
- Bailey, N.G. & Ulrich, G.E. U.S. Geological Survey. (1975). Apollo 15 voice transcript: Pertaining to the geology of the landing site. (USGS-GD-74-029).
<http://www.lpi.usra.edu/lunar/documents/Apollo15VoiceTranscript-Geology.pdf>

- Bailey, N.G. & Ulrich, G.E. U.S. Geological Survey. (1975). Apollo 16 voice transcript: Pertaining to the geology of the landing site. (USGS-GD-74-030). <http://www.lpi.usra.edu/lunar/documents/Apollo16VoiceTranscript-Geology.pdf>
- Bailey, N.G. & Ulrich, G.E. U.S. Geological Survey. (1975). Apollo 17 voice transcript: Pertaining to the geology of the landing site. (USGS-GD-74-031). <https://www.hq.nasa.gov/alsj/a17/Apollo17VoiceTranscript-Geology.pdf>
- Beattie, Donald A. (2001). Taking science to the moon: Luna experiments and the Apollo program. Baltimore: Johns Hopkins University Press.
- Clark, P.E. (2010). Revolution in field science: Apollo approach to inaccessible surface exploration. *Earth Moon Planets*, 106, 133-157. doi: 10.1007/s11038-010-9354-3
- Eckart, Peter. (2006). The lunar base handbook. New York: McGraw-Hill
- Fullerton, Richard K. (2001). Advanced EVA roadmaps and requirements. 31st International Conference on Environmental Systems (ICES), Tokyo, Japan. 2001-01-2200, SAE, 2001.
- Gaier, James R. National Aeronautics and Space Administration. (2005). The effects of lunar dust of EVA systems during the Apollo missions. (NASA/TM-2005-213210). <https://www.hq.nasa.gov/alsj/TM-2005-213610.pdf>
- Goddard, E.N., Mackin, J.H., Shoemaker, E.M. & Waters, A.C. (1965) Objectives of Apollo geological field investigations and proposal for development of an Apollo field exploration system. http://www.lpi.usra.edu/lunar/documents/ap_geology_1965.pdf
- Heiken, Grant H., Vaniman, David T., & French, Bevan M. (1991). Lunar sourcebook: A user's guide to the moon. New York: Cambridge University Press. http://www.lpi.usra.edu/publications/books/lunar_sourcebook/pdf/LunarSourceBook.pdf
- Horanyi, Mihaly & Stern, Alan. (2011). Lunar dust, atmosphere and plasma: The next steps. *Planetary and Space Science*, 59(14), 1671. doi: 10.1016/j.pss.2011.09.007

- Hurtado, José M., Young, Kelsey, Bleacher, Jacob E., Garry, W. Brent & Rice, James W., Jr. (2013). Field geologic observation and sample collection strategies for planetary surface exploration: Insights from the 2010 Desert RATS geologist crewmembers. *Acta Astronautica*, 90(2), 344-355.
doi:10.1016/j.actaastro.2011.10.015
- King, Bert. (1989). *Moon trip: A personal account of the Apollo program and its science*. Houston: University of Houston.
- M'Gonigle, John W., Ables, Paula G. & Regan, Robert D. (1965) Early Apollo investigations field test 5. (Technical Letter: Astrogeology-9).
<http://www.lpi.usra.edu/lunar/strategies/earlyApolloTest5.pdf>
- McSween, Harry Y., Jr. (1999). *Meteorites and their parent planets*. New York: Cambridge University Press.
- National Aeronautics and Space Administration. (1963). Report of the ad hoc working group on Apollo experiments and training on the scientific aspects of the Apollo program. <http://www.lpi.usra.edu/lunar/documents/SonettReport.pdf>
- National Aeronautics and Space Administration. (1969). Apollo 11 mission report. (MSC-00171) http://history.nasa.gov/alsj/a11/A11_MissionReport.pdf
- National Aeronautics and Space Administration. (1969). Apollo 11 preliminary science report. (NASA SP 214). <http://www.hq.nasa.gov/alsj/a11/as11psr.pdf>
- National Aeronautics and Space Administration. (1970). Apollo 12 mission report. (MSC-01855) https://www.hq.nasa.gov/alsj/a12/A12_MissionReport.pdf
- National Aeronautics and Space Administration. (1970). Apollo 12 preliminary science report. (NASA SP 223). <https://www.hq.nasa.gov/alsj/a12/as12psr.pdf>
- National Aeronautics and Space Administration. (1971). Apollo 14 mission report. (MSC-04112). https://www.hq.nasa.gov/alsj/a14/A14_MissionReport.pdf
- National Aeronautics and Space Administration. (1971). Apollo 14 preliminary science report. (NASA SP 272). <https://www.hq.nasa.gov/alsj/a14/as14psr.pdf>
- National Aeronautics and Space Administration. (1971). Apollo 15 mission report. (MSC-05161). <http://history.nasa.gov/alsj/a15/ap15mr.pdf>
- National Aeronautics and Space Administration. (1972). Apollo 15 preliminary science report. (NASA SP 289). <https://www.hq.nasa.gov/alsj/a15/as15psr.pdf>

- National Aeronautics and Space Administration. (1972). Apollo 16 lunar surface procedures. <https://www.hq.nasa.gov/alsj/a16/a16flsp.pdf>
- National Aeronautics and Space Administration. (1972). Apollo 16 mission report. (MSC-07230). https://www.hq.nasa.gov/alsj/a16/A16_MissionReport.pdf
- National Aeronautics and Space Administration. (1972). Apollo 16 preliminary science report. (NASA SP 315). <https://www.hq.nasa.gov/alsj/a16/as16psr.pdf>
- National Aeronautics and Space Administration. (1973) Apollo 17 lunar module onboard voice transcription. (MSC-07630).
http://www.jsc.nasa.gov/history/mission_trans/AS17_LM.PDF
- National Aeronautics and Space Administration. (1973). Apollo 17 mission report. (JSC-07904). https://www.hq.nasa.gov/alsj/a17/A17_MissionReport.pdf
- National Aeronautics and Space Administration. (1973). Apollo 17 preliminary science report. (NASA SP 330). <https://www.hq.nasa.gov/alsj/a17/as17psr.pdf>
- National Aeronautics and Space Administration. (1974). Apollo scientific experiments data handbook. (NASA TM X-58131 / JSC-09166)
<https://www.hq.nasa.gov/alsj/ApolloSciDataHndbk.pdf>
- National Aeronautics and Space Administration. (1975). Apollo Program Summary Report. (JSC-09423). <http://history.nasa.gov/alsj/APSR-JSC-09423.pdf>
- National Aeronautics and Space Administration. (1965). NASA 1965 summer conference of lunar exploration and science. (NASA SP-88).
http://www.lpi.usra.edu/lunar/documents/65_lunar_conf.pdf
- National Aeronautics and Space Administration. (1995). Extravehicular activity (EVA) hardware generic design requirements document. (JSC-26626A).
- National Aeronautics and Space Administration. (1995). Man-systems integration standards (MSIS) volume 1. (NASA-STD-3000).
<http://msis.jsc.nasa.gov/sections/section01.htm>
- National Aeronautics and Space Administration. (2014). Human integration design handbook (HIDH). (NASA/SP-2010-3407/REV1).
- National Aeronautics and Space Administration. (2007) The Apollo operations project: recommendations to improve crew health and performance for future exploration missions and lunar surface operations. (NASA/TM-2007-214755).
<http://ntrs.nasa.gov/archive/nasa/casi.ntrs.nasa.gov/20070030109.pdf>

- National Aeronautics and Space Administration. (2014). Human integration design processes (HIDP) (NASA/TP-2014-218556). http://ston.jsc.nasa.gov/collections/trs/_techrep/TP-2014-218556.pdf
- National Aeronautics and Space Administration. (2015) NASA's journey to Mars. (NP-2015-08-2018-HQ). <http://go.nasa.gov/1VHDXxg>
- National Aeronautics and Space Administration. (2015). JSC design and procedural standards. (JSC-08080-2A). <https://standards.nasa.gov/standard/jsc/jsc-08080-2>
- National Aeronautics and Space Administration. (2015). NASA space flight human-system standard volume 1 revision A: crew health. (NASA-STD-3001). <https://standards.nasa.gov/standard/nasa/nasa-std-3001-vol-1>
- National Aeronautics and Space Administration. (2015). NASA space flight human-system standard volume 2: human factors, habitability, and environmental health. (NASA-STD-3001). <https://standards.nasa.gov/standard/nasa/nasa-std-3001-vol-1>
- National Aeronautics and Space Administration. EVA and Experiments Branch Crew Procedures Division. (1972). Apollo 17 lunar surface procedures. <https://www.hq.nasa.gov/alsj/a17/a17flsp.pdf>
- National Aeronautics and Space Administration. EVA Office. (2005) EVA design requirements and considerations. (JSC-28918)
- National Aeronautics and Space Administration. Lunar Surface Operations Office Mission Operations Branch Flight Crew Division. (1969). Apollo 11 lunar surface operations plan. <https://www.hq.nasa.gov/alsj/a11/a11flsp.pdf>
- National Aeronautics and Space Administration. International Space Station Program. (1997). Extravehicular Activity (EVA) Standard Interface Control Document. (SSP 30256:001, Revision F). http://spacecraft.ssl.umd.edu/design_lib/30256.001F.EVA.ICD.pdf
- National Aeronautics and Space Administration. Lunar Surface Operations Office Mission Operations Branch Flight Crew Support Division. (1969). Apollo 12 lunar surface operations plan. <https://www.hq.nasa.gov/alsj/a12/>
- National Aeronautics and Space Administration. Lunar Surface Operations Office Mission Operations Branch Flight Crew Support Division. (1970). Apollo 14 lunar surface procedures. <https://www.hq.nasa.gov/alsj/a14/as14-flsproc.pdf>

- National Aeronautics and Space Administration. Lunar Surface Procedures Section EVA/IVA Procedures Branch Crew Procedures Division. (1971). Apollo 15 lunar surface procedures. <http://www.hq.nasa.gov/alsj/a15/a15lsp.pdf>
- National Aeronautics and Space Administration. Mission Operations Branch Flight Crew Support Division. (1969). Apollo 11 technical crew debriefing. https://www.hq.nasa.gov/alsj/a11/a11_tcdb.pdf
- National Aeronautics and Space Administration. Mission Operations Branch Flight Crew Support Division. (1969). Apollo 12 technical crew debriefing. <https://www.hq.nasa.gov/alsj/a12/a12techdebrief.pdf>
- National Aeronautics and Space Administration. Mission Operations Branch Flight Crew Division. (1971). Apollo 14 technical crew debriefing. <https://www.hq.nasa.gov/alsj/a14/a14-techdebrief.pdf>
- National Aeronautics and Space Administration. Training Office Crew Training and Simulation Division. (1971). Apollo 15 technical crew debriefing. (MSC-04561) http://www.hq.nasa.gov/alsj/a15/a15_techdebrief.pdf
- National Aeronautics and Space Administration. Training Office Crew Training and Simulation Division. (1972). Apollo 16 technical crew debriefing. (MSC-06805). <https://www.hq.nasa.gov/alsj/a16/a16-techdebrief.pdf>
- National Aeronautics and Space Administration. Training Office Crew Training and Simulation Division. (1973). Apollo 17 technical crew debriefing. (MSC-07631). <https://www.hq.nasa.gov/alsj/a17/>
- National Space Act. (2010). Pub. L. No. 111-267, 124 Stat. 2805 (2010). http://www.nasa.gov/pdf/649377main_PL_111-267.pdf
- O'Brien, B.J. (2012). Apollo measurements of lunar dust amidst geology priorities. *Australian Journal of Earth Sciences*, 59(2), 307-320. doi: 10.1080/08120099.2011.653984
- Phinney, William C. National Aeronautics and Space Administration. (2015). Science training history of the Apollo astronauts. (NASA/SP-2015-626). http://ston.jsc.nasa.gov/collections/TRS/_techrep/SP-2015-626.pdf
- Schaber, Gerald G. U.S. Geological Survey. (2005). The U.S. Geological Survey, Branch of Astrogeology - A chronology of activities from conception through the end of project Apollo (1960-1973). (Open-File Report 2005-1190). <http://pubs.usgs.gov/of/2005/1190/of2005-1190.pdf>

- Shoemaker, E.M., Goddard, E.N., Makcin, J.H., Schmitt, H.H. & Waters, A.C. (1965). Apollo manned lunar landing scientific experiment proposal geological field investigation in early Apollo manned lunar landing missions: Abstract and technical section.
http://www.lpi.usra.edu/lunar/documents/ap_geological_shoemaker_1965.pdf
- Suescun-Florez, Eduardo, Roslyakov, Stanilav, Iskander, Magued, & Baamer, Mohammed. (2015). Geotechnical properties of BP-1 lunar regolith simulant. *Journal of Aerospace Engineering*, 28(5), 1-9. doi: 10.1061/(ASCE)AS.1943-5525.0000462
- Sullivan, Thomas A. National Aeronautics and Space Administration. (1994). Catalog of Apollo experiment operations. (NASA Reference Publication 1317).
<https://www.hq.nasa.gov/alsj/RP-1994-1317.pdf>
- Swann, G.A., Bailey, N.G. & Regan R.D. U.S. Geological Survey. (1967). Apollo applications program field test 5. (Technical Letter: Astrogeology 27).
<http://www.lpi.usra.edu/lunar/strategies/apolloFieldTest.pdf>
- Walton, Otis R. National Aeronautics and Space Administration. (2007). Adhesion of lunar dust. (NASA/CR-2007-214685).
<http://ntrs.nasa.gov/archive/nasa/casi.ntrs.nasa.gov/20070020448.pdf>
- Young, Kelsey, Hurtado, José M., Jr., Bleacher, Jacob E., Garry, W. Brent, Bleisath, Scott, Buffington, Jesse & Rice, James W., Jr. (2013) Tools and technologies needed for conducting planetary field geology while on EVA: Insights from the 2010 Desert RATS geologist crewmembers. *Acta Astronautica*, 90(2), 332-343. doi: :10.1016/j.actaastro.2011.10.016